



This design guide contains application notes for Ledalite luminaires with sensors or radio node controls.

## Control Options

### Basic Daylight and Occupancy 0-10V Sensor (DO):

- See pages 4-5: Option DO Calibration, Configuration and Coverage

### Interact Radio Node (RA) or Interact Sensor Day/Occ (CS):

- See page 6: Interact Foundation/Advance Install & Set-up
- See page 7: Option CS
- See page 9: Interact compatible devices, e.g., MPSW-BT MultiPower Switch

### Interact Enterprise Sensor Bundle Day/Occ + IoT (SB):

- See page 8: Option SB for Enterprise. Commissioned by Signify Services Team
- See page 9: Interact compatible devices, e.g., MPSW-BT MultiPower Switch

### Lutron Athena Radio Node (AR), Lutron Athena Sensor (AS), Lutron Vive Radio Node (VR) or Lutron Vive Sensor (VS):

- [Lutron Support Center](#)
- [Athena Wireless Node](#) [Lutron Athena](#)
- [Vive Integral Luminaire](#) [Lutron Vive](#)

# Wiring Overview

## Important Wiring Restrictions for Luminaires with Sensor or Radio Node Options:

- **DO NOT** connect the purple/pink or purple/brown wires from a luminaire with a sensor or radio node to another sensor or radio node, whether integrated in another luminaire or remotely mounted. This may result in occupancy detection or signal communication conflicts.
- **DO NOT** connect the purple/pink wires from a luminaire with a sensor to a wired external dimmer switch, as this overrides the sensor functionality.
- **DO NOT** connect the purple/pink or purple/brown wires from a luminaire with a sensor or radio node to an external wired DALI control system, as this can cause a control conflict.
- If mains wiring of a luminaire with a sensor or radio node is connected to a circuit with an external on/off switch, this overrides the occupancy detection when mains power is turned off.

## Discrete Recessed Luminaires (Troffers):

### With Integral Controls:

- Discrete luminaires with an integral wireless sensor or radio node are **NOT** supplied with control wires exiting the luminaire.
- Discrete luminaires with a 0-10V sensor have purple/pink control wires exiting the luminaire. **DO NOT** connect these wires to a wired external dimmer switch, as this overrides the sensor functionality. These wires are provided to connect to other 0-10V luminaires (**without** a sensor), allowing a single sensor to control multiple luminaires.

### Without Integral Controls:

- Discrete luminaires without an integral sensor or radio node are supplied with control wires exiting the luminaire, which may be connected to a remote mounted sensor or radio node when a compatible driver is selected. If the fixture is required to be connected to a sensor or controls provided by others, the factory must be contacted to program the driver with auxiliary power supply ON. Auxiliary power is set to OFF by default.

## Linear Luminaires:

All linear luminaires are supplied with control wires exiting the luminaire. The instructions below describe when to connect control wires between adjacent luminaires and when they **must not** be connected.

### Single Sensor Controlling Whole Row

Purple/pink or purple/brown control wires **MUST** be connected between luminaires.

Limited quantity of Sensor Ready drivers can be wired to one sensor; confirm luminaire driver count with factory.



### Multiple Sensors Controlling Separate Zones in a Row

Purple/pink or purple/brown control wires **MUST NOT** be connected between zones.

Limited quantity of Sensor Ready drivers can be wired to one sensor; confirm luminaire driver count with factory.

Only one sensor is allowed in a wired zone. Wireless sensors and radio nodes can be paired via a mobile app.

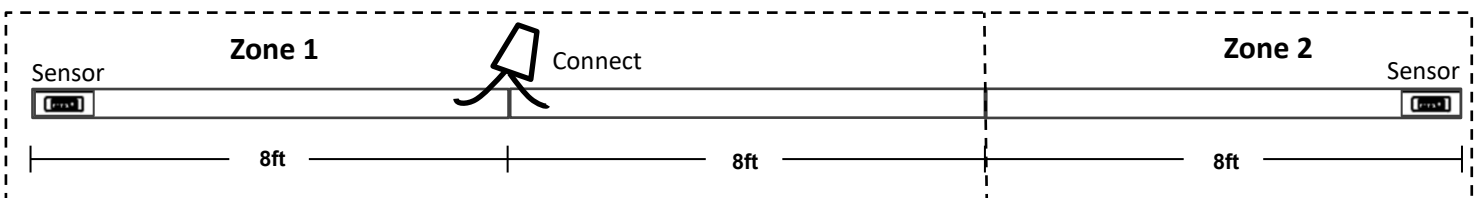

# Sensor or Radio Node Installation

## Sensor Spacing

- For correct operation, sensors should be placed a minimum distance of 8ft apart.
- For good wireless signal communication, Interact wireless sensors or radio nodes should be placed within their maximum spacing: options RA and CS = 15m (49ft), and option SB = 10m (33ft).
- Sensor spacing requirements are different for Lutron controls. Visit Lutron Support Center website for details.

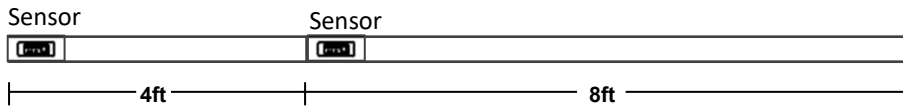

Sensors are too close together for proper operation.

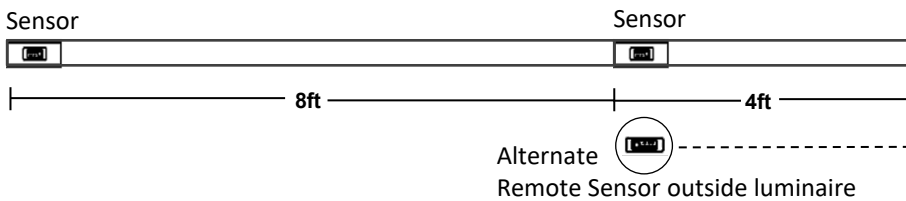

Sensors are at minimum required distance for correct operation.

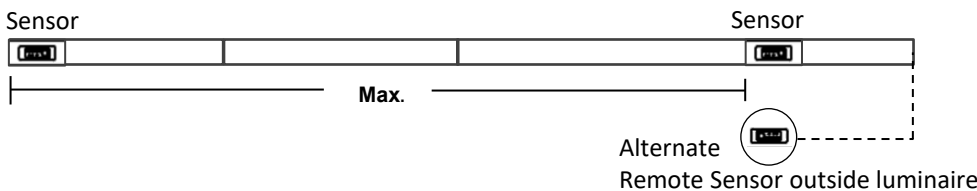

Sensors are within maximum distance apart.

## Important Considerations when using Sensors in Luminaires with Continuous Lens:

- For the best aesthetic condition, place sensors at ends of row only so as not to break the continuous lens.
- For better occupancy coverage in longer rows, sensors may be placed mid run, but keep in mind this will break the continuous lens into discrete sections.
- Remote sensors can be connected to mid run fixtures to avoid a break in the continuous lens.

## Connecting Remote Sensors or Radio Nodes to Remote Driver Pods

- Remote 0-10V sensors should be installed within 100ft of the Driver Pod.
- Remote DALI sensors or radio nodes should be installed within 50ft of the Driver Pod.
- Remote sensors **MUST NOT** be installed above the luminaire to ensure proper line of sight and accurate occupancy detection.
- 18 AWG wires are recommended for connecting sensors or radio nodes to the drivers.
- For correct operation, sensors should be installed at a minimum distance of 8ft apart.
- Ensure wires of the same color are connected between sensors or radio nodes and drivers.

## Connecting Sensors or Radio Nodes to Emergency Devices

When Sensors or radio nodes are connected to luminaires with emergency devices (Bypass Sensor Relay, GTD), the following UL924, section 74.11 requirement applies:

“When this luminaire is designated as part of a facility emergency lighting system and supplied by a remote emergency power source, the control input to the luminaire must be disconnected upon loss of normal facility power. Loss of power to the control input will set the luminaire to either full output or a pre-set illumination level complying with the applicable codes and approved by the authority having jurisdiction.”

# Option DO

# Basic Daylight and Occupancy 0-10V Sensor

## Daylight Calibration Routine

Step-by step instructions for the electrical mains on-off switching routine for daylight calibration in the field.  
 Note: The daylight calibration must be done with limited or no sunlight in the area.

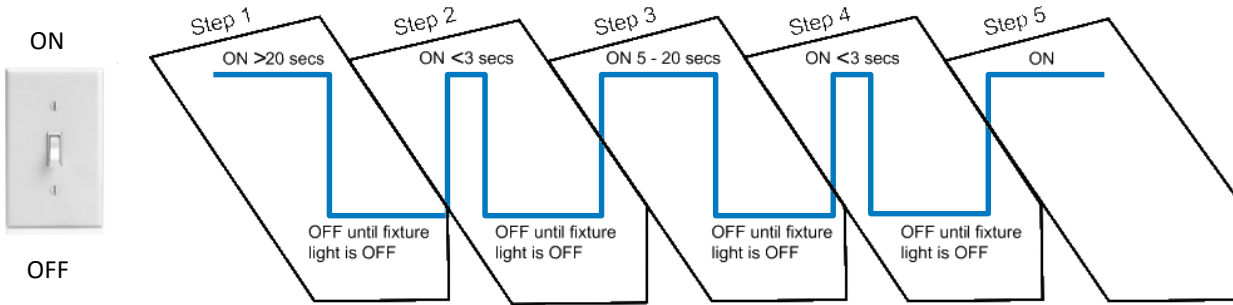

- Step 1 – Light ON for more than 20 seconds, Light OFF;
- Step 2 – Light ON for less than 3 seconds, Light OFF;
- Step 3 – Light ON for more than 5 seconds but less than 20 seconds, Light OFF;
- Step 4 – Light ON for less than 3 seconds, Light OFF;
- Step 5 – Light ON.

~3 seconds after completion of step 5, the fixture light will blink three times to confirm successful calibration of daylight sensing.

Note: If confirmation blinks are not observed, restart the calibration process.

## Configurable Parameters (Dip-switches)

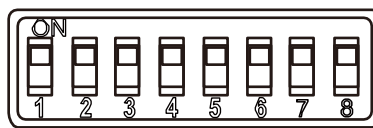
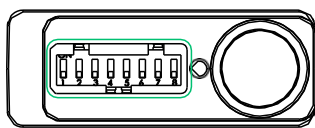

### Daylight Harvesting

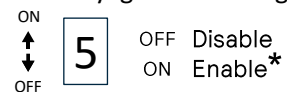

### Task Level

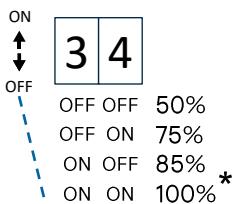

### Background Level

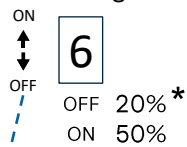

### Hold time

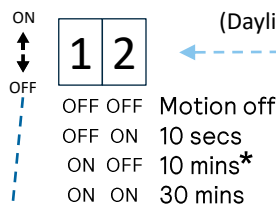

(Daylight sensor works during Hold time)

### Prolong time

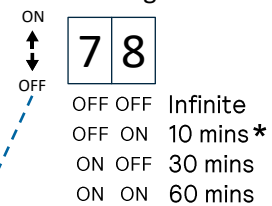

\*Factory Defaults

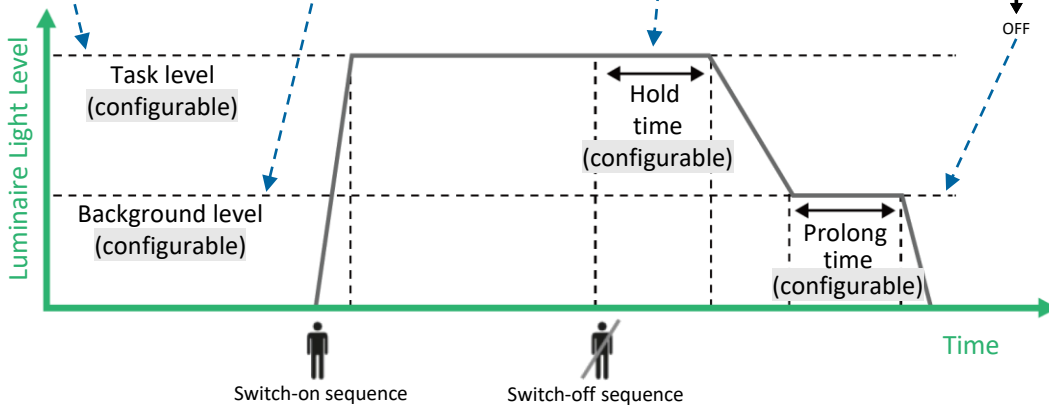

# Option DO

# Basic Daylight and Occupancy 0-10V Sensor

## Occupancy Sensing Coverage (ft)

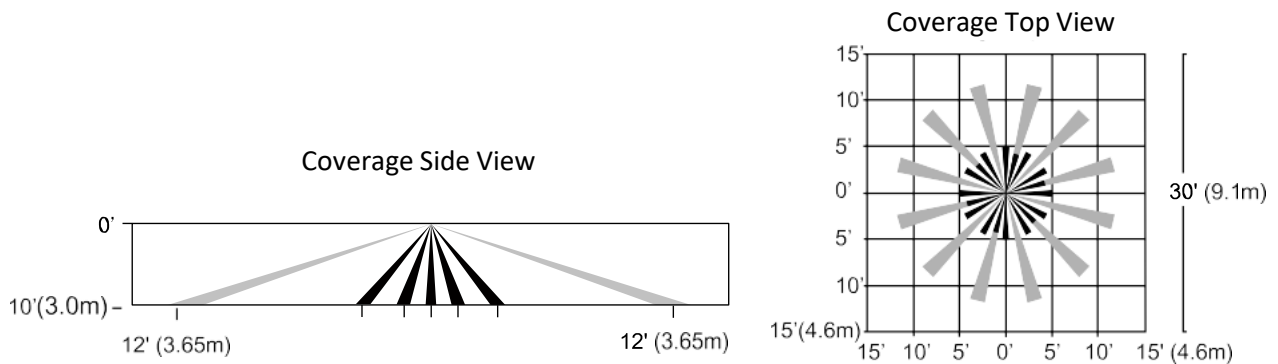

Maximum mounting height 12 ft (3.65 m)

Recommended mounting height 8 - 10 ft (2.5 – 3.0 m)

The detection areas for occupancy sensing are defined as:

- Minor movement (person moving < 3.0 ft/s or 0.9 m/s)
- Major movement (person moving  $\geq$  3.0 ft/s or 0.9 m/s)

### Troubleshooting

The LED will be permanently ON if PIR is malfunctioning. Ensure that the sensor is not located in the direct air flow of a heating or cooling system.

### Wiring

The sensor includes four stranded and tinned 22AWG leads, each measuring 24 inches in length. The wires are color-coded for easy identification.

Note: The sensor may control multiple 0-10V drivers. For full functionality, all drivers **must feature dim to off technology**. The sensor needs AUX source for their power, so they should be used with 0-10V+AUX drivers that support dim to off.

## PRF/PRA Interact Foundation/Advance Install & Setup

*\*not for Enterprise or Signify Commissioned projects*

To configure a lighting system with Interact sensors or radio nodes:

- Ensure the luminaires are installed and powered on.
- Download the Interact Pro app from either Apple's App Store (for iOS) or Google's Play Store.



- Register by tapping **Request access** on the login screen in the app.
- **Click** or **scan** the QR codes below to view instructions for setup.

### Interact Pro Commissioning Guide

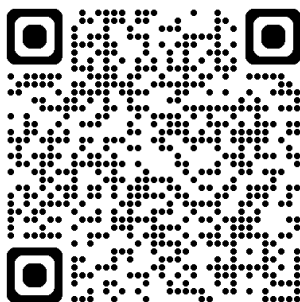

### Interact Pro Setup Video

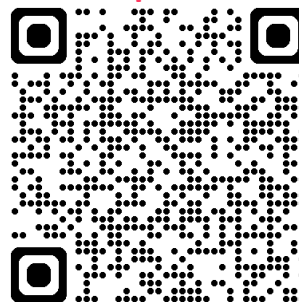

### Interact Pro General Documentation

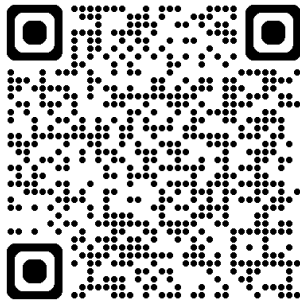

### Contact Us 1-800-555-0050

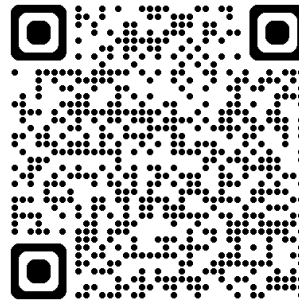

# Option CS

# Interact Sensor Day/Occupancy

## Occupancy Sensor Coverage:

Tested at 21 +/- 3°C (70 +/- 5°F) according to NEMA WD 7-2011

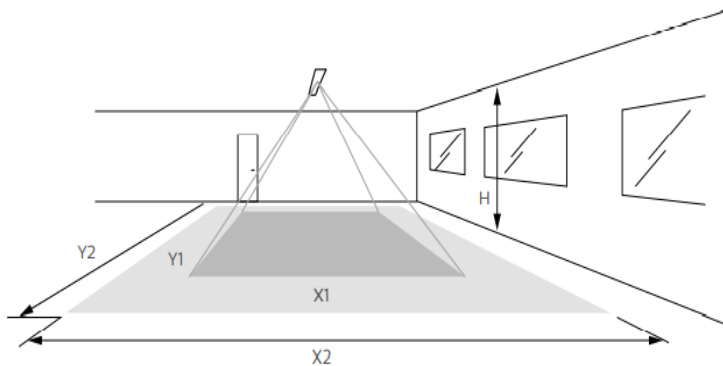

The detection area for the movement sensor can be roughly divided into two parts:

- Minor movement (person moving  $\leq 3\text{ft/s}$  or  $0.9\text{m/s}$ ).
- Major movement (person moving  $\geq 3\text{ft/s}$  or  $0.9\text{m/s}$ ).

Height	Minor Movement		Major Movement	
	X1	Y1	X2	Y2
2.4 m (7.9 ft)	2.7 m (8.9 ft)	2.7 m (8.9 ft)	4.5 m (14.8 ft)	4.5 m (14.8 ft)
2.8 m (9.2 ft)	3.6 m (11.8 ft)	3.6 m (11.8 ft)	5.4 m (17.7 ft)	5.4 m (17.7 ft)
4.0 m (13.1 ft)	3.6 m (11.8 ft)	3.6 m (11.8 ft)	5.4 m (17.7 ft)	5.4 m (17.7 ft)
6.0 m (19.7 ft)	n.a.	n.a.	5.4 m (17.7 ft)	5.4 m (17.7 ft)

## Daylight sensor

The light sensor measures the total amount of light in a circular field of approximately 80% of the PIR detection area. The following aspects should be observed during installation:

- Minimum distance from the window  $\geq 2\text{ft}$  (0.6m).
- Prevent light reflections from outside entering the sensor (for example sunlight reflection on a car hood) as this will lead to incorrect light regulation.

As a guideline the formula  $0.72 \times H$  can be used to calculate the minimum distance between the window and sensor whereby H is the height from the bottom of the window to the sensor.

## Photosensor spatial response

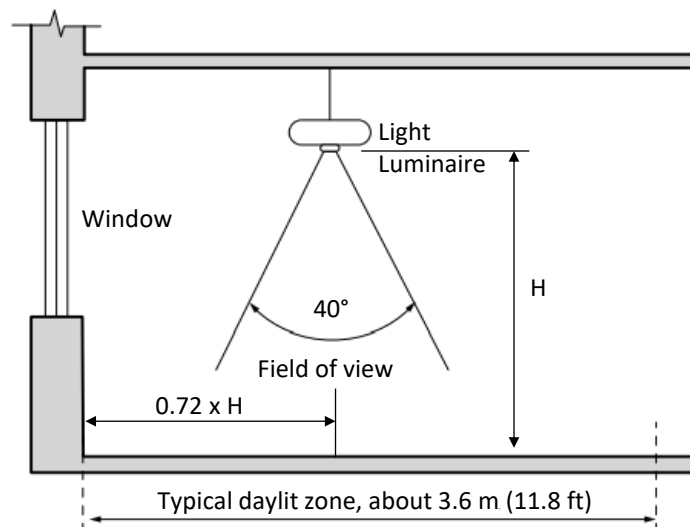

## Wall Mounted Luminaire control

The recommended configuration of wall mounted luminaires with integrated controls is to select a luminaire with an integral radio node connected to another wireless control or a remote wired sensor located above the minor movement zone. If the sensor is in the wall mounted luminaire, the movement detection is limited and is affected by the reflections of light from the wall. The movement detection zone may be additionally reduced as a wall mounted luminaire is typically mounted lower than a suspended or recessed luminaire.

# Option SB Interact Enterprise Sensor Bundle Day/Occ + IoT

For Gateway + IoT      Commissioned by Signify Services Team

## PIR Occupancy Sensing:

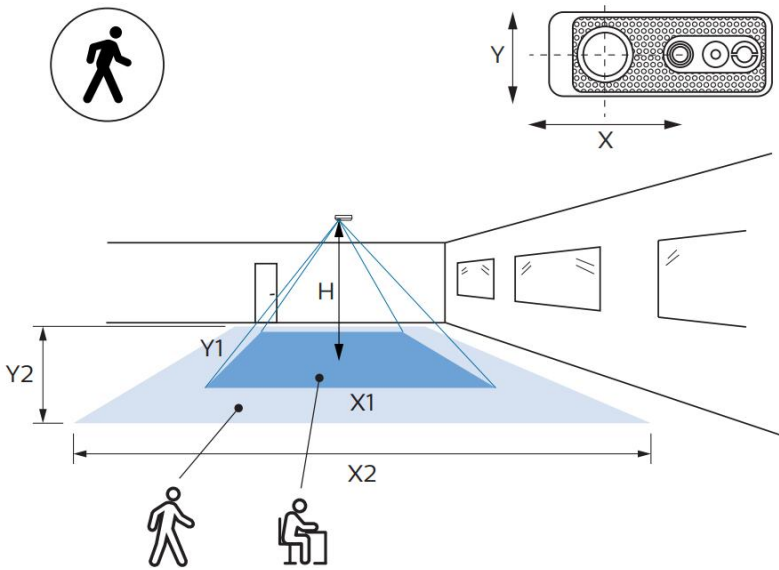

Height	Minor Movement		Major Movement	
h	X1	Y1	X2	Y2
3.0 m (9.8 ft)	3.6 m (11.8 ft)	2.7 m (8.9 ft)	5.4 m (17.7 ft)	3.6 m (11.8 ft)

The detection area is sensed by a thermopile array. By software processing the information is processed to radiant temperature at surface level and people count data.

- Minor movement (person moving  $\leq 3\text{ft/s}$  or  $0.9\text{m/s}$ ).
- Major movement (person moving  $\geq 3\text{ft/s}$  or  $0.9\text{m/s}$ ).

## Daylight sensor

The light sensor measures the total amount of light in a circular field of approximately 80% of the PIR detection area. The following aspects should be observed during installation:

- Minimum distance from the window  $\geq 2\text{ft}$  (0.6m).
- Prevent light reflections from outside entering the sensor (for example sunlight reflection on a car hood) as this will lead to incorrect light regulation.

As a guideline the formula  $0.8 \times H$  can be used to calculate the minimum distance between the window and sensor whereby H is the height from the bottom of the window to the sensor.

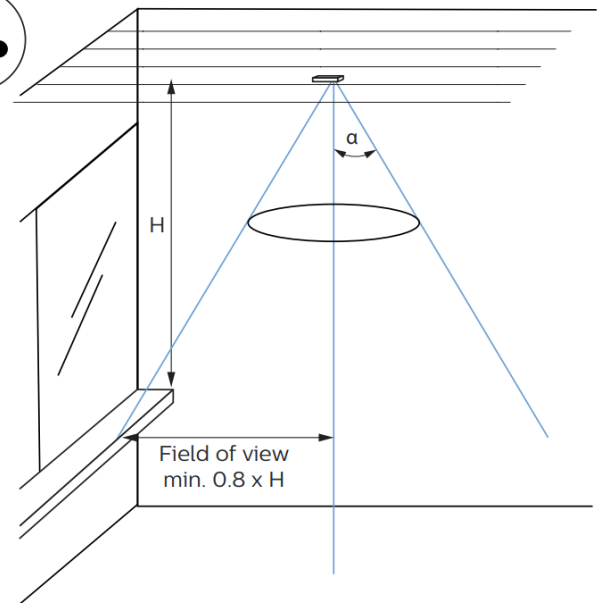

## Sensor Placement

The orientation of the sensor in the luminaire varies by product series.

TruGroove (29, 39), SyncLine (SL), BoldPlay (78)	ArcForm Duo (AF), Pique Duo (PQ), Shine Duo (SH), SilkSpace Duo (SK)	TruGroove Micro (TM, 23), FloatPlane (24), Sona (77)

# Interact Compatible Devices

---

## Compatible Switches

These switches are compatible with Interact Pro system and app.

- UID8465/50 Wireless Switch ([Wireless Switch & Scene Selector](#))
- MPSW-BT/WH MultiPower Switch Battery ([MultiPower Wireless Switch Battery](#))
- MPSW-MN/WH MultiPower Switch Mains ([MultiPower Wireless Switch Mains](#))

## Wireless Switches and Scene Selector (4 button)

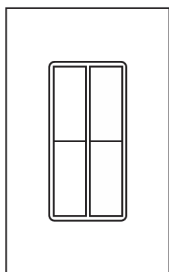

- 912401592572 UID8465/50  
[Installation Wireless Switch](#)

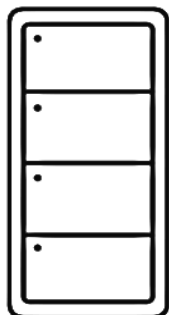

- 913701075813 MPSW-BT/WH (Battery)  
[Installation Wireless Switch](#)

Option battery

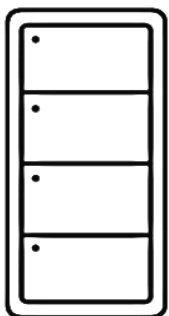
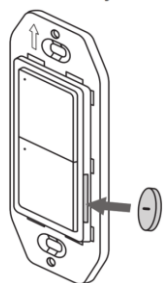

- 913701075913 MPSW-MN/WH (Mains)  
[Installation Wireless Switch](#)

Option 100~277 VAC

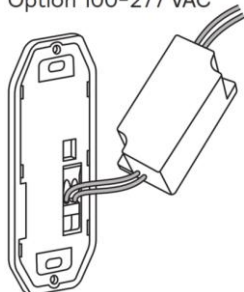

# Interact Compatible Devices

## Wireless Occupancy Sensor

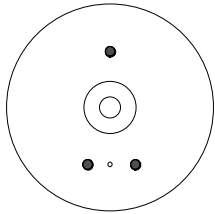

- 913701067013 OCC0100A/02 Battery powered Sensor
- 913701067113 OCC0101A/02 Battery powered Sensor with Daylight Sensing

[Installation Wireless Sensor](#)



## Wired Recessed mounting plate

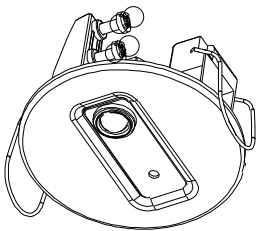

For Options RA & CS:

- 913700359003 LCA8008/05 ActiLume Round Mounting Clip White

For Option SB:

- 913713620603 SA0500/05

Note: Customer supplied plenum rated wire for wired recessed mounting.

[Installation Recessed Mounting Plate](#)



## Wired Surface mounted plate

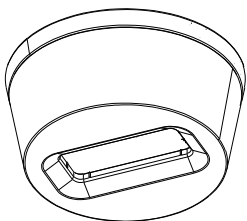

- 913713620813 SA0600/05 Indoor Surface Mount

[Installation Surface Mount Plate](#)

Note: Customer supplied plenum rated wire for wired surface mounting.



**ATTENTION: Install in accordance with local and national building and electrical codes.**