

Day-Brite / CFI DuaLED recessed is a highly efficient, visually comfortable, architecturally styled recessed LED luminaire. Its clean, modern design offers a fresh variation on the popular dual chamber theme and provides architectural styling compatible with virtually any area.

Project: _____
 Location: _____
 Cat.No: _____
 Type: _____
 Qty: _____
 Notes: _____

Ordering guide

Standard configurations available with all choices, unless otherwise noted. Base configuration selections indicated by blue text.

example: 2DLG40B835-2-D-UNV-DIM-DSC

Size	Family	Lumen Package (nom.) ⁵	Color	Length	Center Diffuser D	Voltage	Driver	Options Factory Installed
1x4	1DLG DuaLED Grid	37B 3700lm Base Config.	830 CRI 80, 3000K	4 4'	D Diffuse (opal)	UNV Universal 120-277V	DIM ¹ Dimming LDE ¹ Lutron LDE1 1% DALI DALI SDIM ³ Step dimming to 40% input power	F1 3/8" Flex, 18 ga., 6"; 3 leads (non-dimming)
		27L 2700lm	835 CRI 80, 3500K					F2 3/8" Flex, 18 ga., 6"; 4 leads (emergency, non-dimming)
		36L 3600lm	840 CRI 80, 4000K					F1/D 3/8" Twin Flex, 18 ga., 6"; 3 leads + 2 leads (dimming)
		41L 4100lm	850 CRI 80, 5000K					F2/5W 3/8" Flex, 18 ga., 6"; 5 leads (dimming)
		47L 4700lm	930 CRI 90, 3000K					F2/6W 3/8" Flex, 18 ga., 6"; 6 leads (emergency, dimming)
2x2	2DLG DuaLED Grid	40B 4000lm Base Config.	830 CRI 80, 3000K	2 2'	D Diffuse (opal)	UNV Universal 120-277V	DIM ¹ Dimming LDE ¹ Lutron LDE1 1% DALI DALI SDIM ³ Step dimming to 40% input power	GLR Fusing, Fast Blow
		27L 2700lm	835 CRI 80, 3500K					DSC Quick driver disconnect
		30L 3000lm	840 CRI 80, 4000K					CHIC Chicago Plenum rated
		34L 3400lm	850 CRI 80, 5000K					EM10 Bodine 10W battery pack (requires driver enclosure on top of luminaire)
		38L 3800lm	930 CRI 90, 3000K					ER100 ¹⁰ UL924 listed sensor bypass relay, factory installed between driver & sensor
2x4	2DLG DuaLED Grid	42B 4200lm Base Config.	830 CRI 80, 3000K	4 4'	D Diffuse (opal)	UNV Universal 120-277V	DIM ¹ Dimming LDE ¹ Lutron LDE1 1% DALI DALI SDIM ³ Step dimming to 40% input power	GTD/E ^{4,9} UL924 listed Bodine GTD factory installed on driver input
		43L 4300lm	835 CRI 80, 3500K					GTD/SNSR ¹⁰ UL924 listed Bodine GTD factory installed between driver and sensor
		49L 4900lm	840 CRI 80, 4000K					SWZCS ^{6,8,11} Interact wireless sensor with daylight, occupancy, and advanced grouping with dwell time
		58L 5800lm	850 CRI 80, 5000K					SWZCSR ^{6,8,12} Remote Interact wireless sensor with daylight, occupancy, and advanced grouping with dwell time
		73L 7300lm	930 CRI 90, 3000K					IAOSB ^{6,8,11} Interact wireless sensor bundle with daylight, occupancy, and environmental sensing capabilities
								RADIO ^{6,7} Interact RF sensor for wireless connectivity only, no integral sensing
								AG Antimicrobial paint

Footnotes

- Integral controls options dimmable to 5% via wireless wall switch. Non-controls options are 0-10v dimmable to 1% for Standard configurations, and 10% for Base configurations.
- LDE1 option only available for 27L and 36L lumen packages on 1x4 size; 27L, 34L, 38L, and 44L on 2x2 size; and 43L on 2x4 size.
- 58L and 73L not available with the SDIM option.
- Not available with 347V option.
- Other lumen packages may be ordered in increments of 100lm between the lowest and highest Standard lumen packages listed for each size.
- Specify DIM driver option only.
- Not available with surface or suspended accessories.
- Must order IRT9015 Interact commissioning remote with each system order.
- Must be installed in conjunction with a UL1008 device.
- Must be ordered with an integral controls option.
- Not available on 1x4 sizes.
- Not available on 2x2 and 2x4 sizes.

Accessories (order separately)

- FMA14 1'x4' "F" mounting frame for NEMA "F" mounting
- FMA22 2'x2' "F" mounting frame for NEMA "F" mounting
- FMA24 2'x4' "F" mounting frame for NEMA "F" mounting
- FSK14 1'x4' surface mount field installation kit (welded seams, not available with emergency options)
- FSK22 2'x2' surface mount field installation kit (welded seams, not available with emergency options)
- FSK24 2'x4' surface mount field installation kit (welded seams, not available with emergency options)
- FSF14 1'x4' surface mount field assembly kit (field assembled, not available with emergency options)
- FSF22 2'x2' surface mount field assembly kit (field assembled, not available with emergency options)
- FSF24 2'x4' surface mount field assembly kit (field assembled, not available with emergency options)
- IRT9015 Interact handheld remote for grouping and configuration (at least one remote required for any Interact installation)

DLG DualLED Recessed

1'x4', 2'x2', & 2'x4'

Application

- Low profile configuration is only 2-11/16" high and is compatible with virtually any plenum.
- Designed for use with standard Grid (NEMA "G") or Narrow Grid (NEMA "NFG") ceiling T-bars. Drywall or plaster requirements can be accommodated by using an FMA "F" mounting frame (sold separately).
- Listed for use in non-insulated ceilings (Type Non-IC).
- Some DualLED luminaires are DesignLights Consortium® qualified. Please see the DLC QPL list for exact catalog numbers, www.designlights.org/QPL.

Construction/Finish

- Luminaire is painted after fabrication with a matte white polyester powder coating for a high quality, durable finish with no unfinished edges to create an installation hazard or potential for corrosion.
- T-bar grid clips are included for easy installation.

Electrical

- Integral sensor options for occupancy sensing and/or daylight harvesting are available for additional energy savings with no reduction of life or increase in installation labor.
- Driver and LED boards are easily accessible from below without tools. Multiple LED boards are individually replaceable if needed via plug-in connectors to ensure long service life.
- Emergency options are available to add even more application flexibility. Emergency models require a top mounted driver enclosure or a metal can emergency driver mounted to the housing/top enclosure that increases luminaire depth.
- 5 year manufacturer's limited warranty. Visit <https://www.genlyte.com/en-us/support/warranties> for complete warranty information.
- Predicted L70 lumen maintenance up to 70,000 hours for Standard configurations and 50,000 hours for Base configurations.
 - To estimate lumen output in emergency mode, multiply emergency pack wattage by luminaire efficacy, then by 1.10. Typical lumen output is 1300lm for EM10.

- The GTD/E option is used to bypass wall switches and allow luminaire operation on auxiliary power. Generator transfer requires installation in conjunction with a UL1008 listed device.
- The GTD/SNSR option is used to bypass integrated sensor control in the event of utility power loss. Generator transfer requires installation in conjunction with a UL1008 listed device.
- cETLus listed to UL and CSA standards. Standard DualLED suitable for damp locations.

Enclosure

- Dual chamber configuration utilizes two diffusers with large surface area for brightness control.
- Opal diffusers provide soft, comfortable lighting while maintaining high efficiency.
- Diffusers require no frames or fasteners and can be easily removed from below without tools if needed.

General Notes

- All options factory installed.
- All accessories are field installed.
- Many luminaire components, such as reflectors, refractors, lenses, sockets, lampholders, and LEDs are made from various types of plastics which can be adversely affected by airborne contaminants. If sulfur based chemicals, petroleum based products, cleaning solutions, or other contaminants are expected in the intended area of use, consult factory for compatibility.

CRI 90 Lumen Adjustment

CCT	Multiplier
3000K	0.97
3500K	0.95
4000K	0.95
5000K	0.93

Use the numbers above to calculate CRI 90 lumen output from CRI 80 data.

DualLED shown with integral sensor



SWZCS sensor shown (2x2 and 2x4)

Energy Data

Luminaire	Catalog Number	Input Power (W)	Efficacy (lm/W)
1x4 Base	1DLG37B840	34	126
	1DLG27L840	22	127
1x4 Standard	1DLG36L840	29	123
	1DLG41L840	34	121
	1DLG47L840	39	120
2x2 Base	2DLG40B840	34	126
	2DLG27L840	22	126
2x2 Standard	2DLG30L840	25	126
	2DLG34L840	27	129
	2DLG38L840	31	126
	2DLG44L840	36	124
2x4 Base	2DLG42B840	33	136
	2DLG43L840	32	136
2x4 Standard	2DLG49L840	37	136
	2DLG58L840	44	134
	2DLG73L840	55	133

Dimensions 1x4

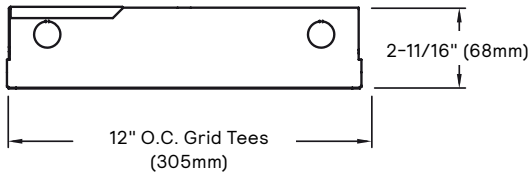

Dimensions 2x4 and 4x4

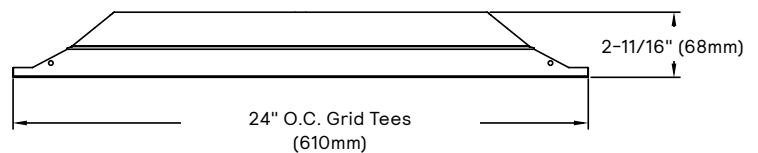

* EM10 options are 1-3/4" (45mm) deeper

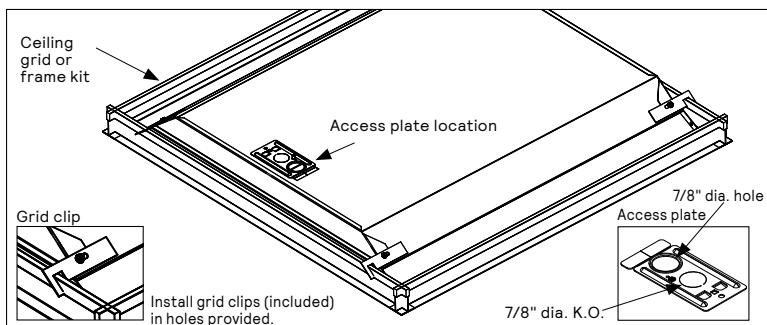

DLG DuaLED Recessed

1'x4', 2'x2', & 2'x4'

@signify interact **Easy. Effective. Smart.**

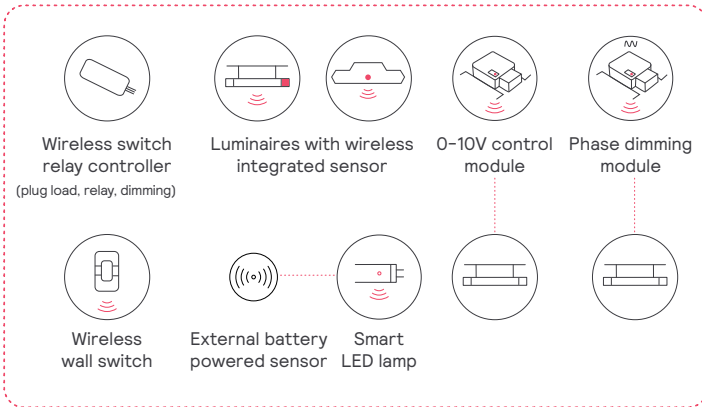

Meet Interact

A smart, wireless luminaire level lighting control system (LLLLC). A complete solution that combines modern and intuitive technologies for easy installation and specification.

- Works with or without gateway
- **No** IT
- **No** light point restrictions
- **Up to 75%** out of the box savings
- **Fast & easy**
- **Code & rebates** compliant

Capabilities



*Grouping, zoning, dimming, high-end trimming, scenes, scheduling, manual controls

Benefits

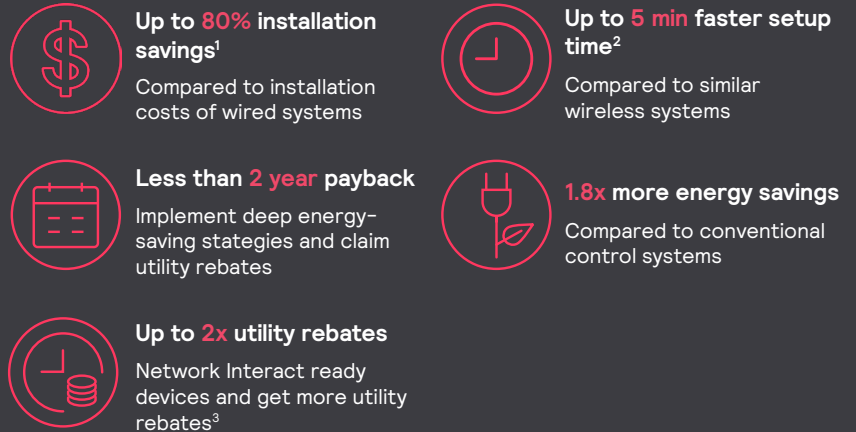

1. Versus legacy systems based on installer interviews
2. Based on installer analysis done by Signify for a typical multi-zone space
3. Utility programs across US

Just lights and an App



1. Install the Interact ready fixtures with embedded smart sensor
2. Install the wireless wall switch
3. Configure your setup with the Interact App
4. Leverage the IRT9015 remote accessory to accelerate your setup process
5. Optionally add a gateway for insights and management

Learn more about Interact:

Interact includes an app, a web portal, and a comprehensive range of Interact ready wireless luminaires, lamps, retrofit kits, and control devices like switches and sensors that operate within the same system.



DLG DuaLED Recessed

1'x4', 2'x2', & 2'x4'

Controls Options*

Interact radio node for Standalone,

Gateway & Gateway + IoT tiers (RA)

- RA sensor option is a connected radio node supporting wireless mesh connectivity.
- Compatible with standalone and gateway modes of Interact.

Interact occupancy & daylight sensor for Standalone, Gateway & Gateway + IoT tiers

(CS)

- The CS sensor option is a connected sensor with built-in occupancy and daylight detection, along with wireless mesh connectivity.
- Compatible with standalone and gateway modes of Interact.

Interact advanced sensor bundle for

Gateway + IoT tier (SB)

- SB sensor option offers occupancy and daylight sensing and supports advanced IoT capabilities, such as desk-level temperature and humidity monitoring, noise classification, and Bluetooth Low Energy (BLE) beacon functionality.
- Setup requires a compatible gateway and internet connectivity.
- With compatible gateway and software analytics, SB sensor option enables greater building efficiency, seamless system integration, and optimized space utilization through occupancy and environmental insights.

Interact for intelligent buildings sensor option codes across Genlyte product lines*

	Sensor part #	Daybrite	Ledalite	Lightolier
Zigbee + Bluetooth	SC100B	RADIO	RA	RA
Zigbee + Bluetooth + Sensing	SC200B	SWZCS	CS	SBA or SWCS accessory
Zigbee + Bluetooth + Sensing + Environmental data	SC1500	IAOSB	SB	SBA or SWCS accessory
Zigbee + Highbay + Bluetooth + Sensing	SNH210 IA	SWZCSH	-	-

DLG DuaLED Recessed

1'x4', 2'x2', & 2'x4'

Photometry

1x4 DuaLED, 3700 nominal delivered lumens

LER - 111

Catalog No. 1DLG37B840-4-D-UNV Test No. 37670 S/MH 1.3 Lamp Type LED Lumens/Lamp 3738 Input Watts 34	Candela distribution Vertical Angle Horizontal Angle 0° 45° 90° -45°				Light Distribution Degrees Lumens % Luminaire			Average Luminance Angle End 45° Cross			
	0 1284 1284 1284 1284 5 1266 1277 1283 1277 15 1223 1235 1239 1235 25 1138 1149 1157 1149 35 1013 1025 1035 1025 45 854 876 883 876 55 669 694 700 694 65 466 474 471 474 75 244 249 245 249 85 72 64 63 64	0-30 1000 26.7 0-40 1642 43.9 0-60 2930 78.4 0-90 3738 100.0	45 5378 5514 5559 55 5194 5384 5434 65 4911 4996 4960 75 4198 4276 4207 85 3662 3289 3223								
Comparative yearly lighting energy cost per 1000 lumens - \$2.16 based on 3000 hrs. and \$.08 pwr KWH. The photometric results were obtained in the Day-Brite laboratory which is NVLAP accredited by the National Institute of Standards and Technology. Photometric values based on test performed in compliance with LM-79.	Coefficients of Utilization EFFECTIVE FLOOR CAVITY REFLECTANCE 20 PER (pfc=0.20)										
Ceiling (pcc) 80% 70% 50%		Wall (pw) 70 50 30 70 50 30 50 30									
RCR Zonal cavity method - Effective floor reflectance = 20%		Room Cavity Ratio 0 118 118 118 115 115 115 111 111 1 109 104 98 106 101 96 96 93 2 98 90 82 95 88 81 84 79 3 90 79 70 86 77 69 73 68 4 81 69 60 80 68 59 66 58 5 75 61 53 72 60 53 58 52 6 69 56 46 68 55 46 53 46 7 65 51 41 63 50 41 47 40 8 59 46 38 57 46 36 44 36 9 56 42 34 55 41 34 40 33 10 53 39 30 51 39 30 38 30									

1x4 DuaLED, 3600 nominal delivered lumens

LER - 123

Catalog No. 1DLG36L840-4-D-UNV-DIM Test No. 35432 S/MH 1.3 Lamp Type LED Lumens/Lamp 3567 Input Watts 29.0	Candela distribution Vertical Angle Horizontal Angle 0° 45° 90° -45°				Light Distribution Degrees Lumens % Luminaire			Average Luminance Angle End 45° Cross			
	0 1218 1218 1218 1218 5 1200 1214 1222 1214 15 1159 1179 1186 1179 25 1077 1095 1106 1095 35 954 979 992 979 45 802 831 845 831 55 625 655 668 655 65 433 459 461 459 75 243 247 246 247 85 73 62 66 62	0-30 952 26.7 0-40 1563 43.8 0-60 2782 78.0 0-90 3568 100.0	45 5321 5512 5607 55 5111 5357 5465 65 4805 5099 5116 75 4402 4476 4462 85 3925 3333 3526								
Comparative yearly lighting energy cost per 1000 lumens - \$1.95 based on 3000 hrs. and \$.08 pwr KWH. The photometric results were obtained in the Day-Brite laboratory which is NVLAP accredited by the National Institute of Standards and Technology. Photometric values based on test performed in compliance with LM-79.	Coefficients of Utilization EFFECTIVE FLOOR CAVITY REFLECTANCE 20 PER (pfc=0.20)										
Ceiling (pcc) 80% 70% 50%		Wall (pw) 70 50 30 70 50 30 50 30									
RCR Zonal cavity method - Effective floor reflectance = 20%		Room Cavity Ratio 0 118 118 118 115 115 115 111 111 1 108 104 98 106 101 96 96 93 2 97 90 82 95 88 81 84 79 3 90 79 70 86 77 69 73 68 4 81 69 60 80 68 59 66 58 5 75 61 53 72 60 53 58 51 6 69 56 46 68 55 46 53 46 7 64 51 41 63 50 41 47 40 8 59 46 38 57 46 36 44 36 9 56 41 34 55 41 34 40 33 10 52 39 30 51 39 30 38 30									

DLG DuaLED Recessed

1'x4', 2'x2', & 2'x4'

1x4 DuaLED, 4100 nominal delivered lumens

LER - 121

Catalog No. 1DLG41L840-4-D-UNV-DIM Test No. 35433 S/MH 1.3 Lamp Type LED Lumens/Lamp 4220 Input Watts 34.7	Candela distribution <table border="1"> <thead> <tr> <th rowspan="2">Vertical Angle</th> <th colspan="4">Horizontal Angle</th> </tr> <tr> <th>0°</th> <th>45°</th> <th>90°</th> <th>-45°</th> </tr> </thead> <tbody> <tr><td>0</td><td>1440</td><td>1440</td><td>1440</td><td>1440</td></tr> <tr><td>5</td><td>1418</td><td>1435</td><td>1445</td><td>1435</td></tr> <tr><td>15</td><td>1371</td><td>1394</td><td>1402</td><td>1394</td></tr> <tr><td>25</td><td>1273</td><td>1295</td><td>1308</td><td>1295</td></tr> <tr><td>35</td><td>1129</td><td>1157</td><td>1173</td><td>1157</td></tr> <tr><td>45</td><td>948</td><td>981</td><td>1000</td><td>981</td></tr> <tr><td>55</td><td>739</td><td>774</td><td>791</td><td>774</td></tr> <tr><td>65</td><td>513</td><td>543</td><td>546</td><td>543</td></tr> <tr><td>75</td><td>287</td><td>293</td><td>291</td><td>293</td></tr> <tr><td>85</td><td>86</td><td>74</td><td>78</td><td>74</td></tr> </tbody> </table>	Vertical Angle	Horizontal Angle				0°	45°	90°	-45°	0	1440	1440	1440	1440	5	1418	1435	1445	1435	15	1371	1394	1402	1394	25	1273	1295	1308	1295	35	1129	1157	1173	1157	45	948	981	1000	981	55	739	774	791	774	65	513	543	546	543	75	287	293	291	293	85	86	74	78	74	Light Distribution <table border="1"> <thead> <tr> <th>Degrees</th> <th>Lumens</th> <th>% Luminaire</th> </tr> </thead> <tbody> <tr><td>0-30</td><td>1126</td><td>26.7</td></tr> <tr><td>0-40</td><td>1849</td><td>43.8</td></tr> <tr><td>0-60</td><td>3292</td><td>78.0</td></tr> <tr><td>0-90</td><td>4222</td><td>100.0</td></tr> </tbody> </table>	Degrees	Lumens	% Luminaire	0-30	1126	26.7	0-40	1849	43.8	0-60	3292	78.0	0-90	4222	100.0	Average Luminance <table border="1"> <thead> <tr> <th>Angle</th> <th>End</th> <th>45°</th> <th>Cross</th> </tr> </thead> <tbody> <tr><td>45</td><td>6293</td><td>6508</td><td>6636</td></tr> <tr><td>55</td><td>6049</td><td>6329</td><td>6472</td></tr> <tr><td>65</td><td>5690</td><td>6033</td><td>6057</td></tr> <tr><td>75</td><td>5210</td><td>5303</td><td>5279</td></tr> <tr><td>85</td><td>4646</td><td>3957</td><td>4183</td></tr> </tbody> </table>	Angle	End	45°	Cross	45	6293	6508	6636	55	6049	6329	6472	65	5690	6033	6057	75	5210	5303	5279	85	4646	3957	4183																														
			Vertical Angle	Horizontal Angle																																																																																																																															
0°	45°	90°		-45°																																																																																																																															
0	1440	1440	1440	1440																																																																																																																															
5	1418	1435	1445	1435																																																																																																																															
15	1371	1394	1402	1394																																																																																																																															
25	1273	1295	1308	1295																																																																																																																															
35	1129	1157	1173	1157																																																																																																																															
45	948	981	1000	981																																																																																																																															
55	739	774	791	774																																																																																																																															
65	513	543	546	543																																																																																																																															
75	287	293	291	293																																																																																																																															
85	86	74	78	74																																																																																																																															
Degrees	Lumens	% Luminaire																																																																																																																																	
0-30	1126	26.7																																																																																																																																	
0-40	1849	43.8																																																																																																																																	
0-60	3292	78.0																																																																																																																																	
0-90	4222	100.0																																																																																																																																	
Angle	End	45°	Cross																																																																																																																																
45	6293	6508	6636																																																																																																																																
55	6049	6329	6472																																																																																																																																
65	5690	6033	6057																																																																																																																																
75	5210	5303	5279																																																																																																																																
85	4646	3957	4183																																																																																																																																
Comparative yearly lighting energy cost per 1000 lumens - \$1.97 based on 3000 hrs. and \$.08 pwr KWH. The photometric results were obtained in the Day-Brite laboratory which is NVLAP accredited by the National Institute of Standards and Technology. Photometric values based on test performed in compliance with LM-79.	Coefficients of Utilization EFFECTIVE FLOOR CAVITY REFLECTANCE 20 PER (pfc=0.20)			<table border="1"> <thead> <tr> <th rowspan="2">Ceiling (pcc)</th> <th colspan="3">80%</th> <th colspan="3">70%</th> <th colspan="3">50%</th> </tr> <tr> <th>70</th> <th>50</th> <th>30</th> <th>70</th> <th>50</th> <th>30</th> <th>50</th> <th>30</th> </tr> </thead> <tbody> <tr> <td>RCR</td> <td colspan="9">Zonal cavity method - Effective floor reflectance = 20%</td> </tr> <tr><td>0</td><td>118</td><td>118</td><td>118</td><td>115</td><td>115</td><td>115</td><td>111</td><td>111</td></tr> <tr><td>1</td><td>108</td><td>104</td><td>98</td><td>106</td><td>101</td><td>96</td><td>96</td><td>93</td></tr> <tr><td>2</td><td>97</td><td>90</td><td>82</td><td>95</td><td>88</td><td>81</td><td>84</td><td>79</td></tr> <tr><td>3</td><td>90</td><td>79</td><td>70</td><td>86</td><td>77</td><td>69</td><td>73</td><td>68</td></tr> <tr><td>4</td><td>81</td><td>69</td><td>60</td><td>80</td><td>68</td><td>59</td><td>66</td><td>58</td></tr> <tr><td>5</td><td>75</td><td>61</td><td>53</td><td>72</td><td>60</td><td>53</td><td>58</td><td>51</td></tr> <tr><td>6</td><td>69</td><td>56</td><td>46</td><td>68</td><td>55</td><td>46</td><td>53</td><td>46</td></tr> <tr><td>7</td><td>64</td><td>51</td><td>41</td><td>63</td><td>50</td><td>41</td><td>47</td><td>40</td></tr> <tr><td>8</td><td>59</td><td>46</td><td>38</td><td>57</td><td>46</td><td>36</td><td>44</td><td>36</td></tr> <tr><td>9</td><td>56</td><td>41</td><td>34</td><td>55</td><td>41</td><td>34</td><td>40</td><td>33</td></tr> <tr><td>10</td><td>52</td><td>39</td><td>30</td><td>51</td><td>39</td><td>30</td><td>38</td><td>30</td></tr> </tbody> </table>	Ceiling (pcc)	80%			70%			50%			70	50	30	70	50	30	50	30	RCR	Zonal cavity method - Effective floor reflectance = 20%									0	118	118	118	115	115	115	111	111	1	108	104	98	106	101	96	96	93	2	97	90	82	95	88	81	84	79	3	90	79	70	86	77	69	73	68	4	81	69	60	80	68	59	66	58	5	75	61	53	72	60	53	58	51	6	69	56	46	68	55	46	53	46	7	64	51	41	63	50	41	47	40	8	59	46	38	57	46	36	44	36	9	56	41	34	55	41	34	40	33	10	52	39	30	51	39	30	38	30
Ceiling (pcc)	80%					70%			50%																																																																																																																										
	70	50	30	70	50	30	50	30																																																																																																																											
RCR	Zonal cavity method - Effective floor reflectance = 20%																																																																																																																																		
0	118	118	118	115	115	115	111	111																																																																																																																											
1	108	104	98	106	101	96	96	93																																																																																																																											
2	97	90	82	95	88	81	84	79																																																																																																																											
3	90	79	70	86	77	69	73	68																																																																																																																											
4	81	69	60	80	68	59	66	58																																																																																																																											
5	75	61	53	72	60	53	58	51																																																																																																																											
6	69	56	46	68	55	46	53	46																																																																																																																											
7	64	51	41	63	50	41	47	40																																																																																																																											
8	59	46	38	57	46	36	44	36																																																																																																																											
9	56	41	34	55	41	34	40	33																																																																																																																											
10	52	39	30	51	39	30	38	30																																																																																																																											

1x4 DuaLED, 4700 nominal delivered lumens

LER - 120

Catalog No. 1DLG47L840-4-D-UNV-DIM Test No. 35436 S/MH 1.3 Lamp Type LED Lumens/Lamp 4706 Input Watts 39.1	Candela distribution <table border="1"> <thead> <tr> <th rowspan="2">Vertical Angle</th> <th colspan="4">Horizontal Angle</th> </tr> <tr> <th>0°</th> <th>45°</th> <th>90°</th> <th>-45°</th> </tr> </thead> <tbody> <tr><td>0</td><td>1606</td><td>1606</td><td>1606</td><td>1606</td></tr> <tr><td>5</td><td>1581</td><td>1603</td><td>1611</td><td>1603</td></tr> <tr><td>15</td><td>1528</td><td>1556</td><td>1564</td><td>1556</td></tr> <tr><td>25</td><td>1419</td><td>1447</td><td>1459</td><td>1447</td></tr> <tr><td>35</td><td>1257</td><td>1292</td><td>1307</td><td>1292</td></tr> <tr><td>45</td><td>1056</td><td>1096</td><td>1114</td><td>1096</td></tr> <tr><td>55</td><td>823</td><td>865</td><td>881</td><td>865</td></tr> <tr><td>65</td><td>571</td><td>606</td><td>606</td><td>606</td></tr> <tr><td>75</td><td>319</td><td>325</td><td>324</td><td>325</td></tr> <tr><td>85</td><td>96</td><td>81</td><td>86</td><td>81</td></tr> </tbody> </table>	Vertical Angle	Horizontal Angle				0°	45°	90°	-45°	0	1606	1606	1606	1606	5	1581	1603	1611	1603	15	1528	1556	1564	1556	25	1419	1447	1459	1447	35	1257	1292	1307	1292	45	1056	1096	1114	1096	55	823	865	881	865	65	571	606	606	606	75	319	325	324	325	85	96	81	86	81	Light Distribution <table border="1"> <thead> <tr> <th>Degrees</th> <th>Lumens</th> <th>% Luminaire</th> </tr> </thead> <tbody> <tr><td>0-30</td><td>1256</td><td>26.7</td></tr> <tr><td>0-40</td><td>2062</td><td>43.8</td></tr> <tr><td>0-60</td><td>3671</td><td>78.0</td></tr> <tr><td>0-90</td><td>4708</td><td>100.0</td></tr> </tbody> </table>	Degrees	Lumens	% Luminaire	0-30	1256	26.7	0-40	2062	43.8	0-60	3671	78.0	0-90	4708	100.0	Average Luminance <table border="1"> <thead> <tr> <th>Angle</th> <th>End</th> <th>45°</th> <th>Cross</th> </tr> </thead> <tbody> <tr><td>45</td><td>7007</td><td>7274</td><td>7394</td></tr> <tr><td>55</td><td>6734</td><td>7075</td><td>7205</td></tr> <tr><td>65</td><td>6335</td><td>6728</td><td>6732</td></tr> <tr><td>75</td><td>5785</td><td>5887</td><td>5878</td></tr> <tr><td>85</td><td>5141</td><td>4345</td><td>4603</td></tr> </tbody> </table>	Angle	End	45°	Cross	45	7007	7274	7394	55	6734	7075	7205	65	6335	6728	6732	75	5785	5887	5878	85	5141	4345	4603																														
			Vertical Angle	Horizontal Angle																																																																																																																															
0°	45°	90°		-45°																																																																																																																															
0	1606	1606	1606	1606																																																																																																																															
5	1581	1603	1611	1603																																																																																																																															
15	1528	1556	1564	1556																																																																																																																															
25	1419	1447	1459	1447																																																																																																																															
35	1257	1292	1307	1292																																																																																																																															
45	1056	1096	1114	1096																																																																																																																															
55	823	865	881	865																																																																																																																															
65	571	606	606	606																																																																																																																															
75	319	325	324	325																																																																																																																															
85	96	81	86	81																																																																																																																															
Degrees	Lumens	% Luminaire																																																																																																																																	
0-30	1256	26.7																																																																																																																																	
0-40	2062	43.8																																																																																																																																	
0-60	3671	78.0																																																																																																																																	
0-90	4708	100.0																																																																																																																																	
Angle	End	45°	Cross																																																																																																																																
45	7007	7274	7394																																																																																																																																
55	6734	7075	7205																																																																																																																																
65	6335	6728	6732																																																																																																																																
75	5785	5887	5878																																																																																																																																
85	5141	4345	4603																																																																																																																																
Comparative yearly lighting energy cost per 1000 lumens - \$2.00 based on 3000 hrs. and \$.08 pwr KWH. The photometric results were obtained in the Day-Brite laboratory which is NVLAP accredited by the National Institute of Standards and Technology. Photometric values based on test performed in compliance with LM-79.	Coefficients of Utilization EFFECTIVE FLOOR CAVITY REFLECTANCE 20 PER (pfc=0.20)			<table border="1"> <thead> <tr> <th rowspan="2">Ceiling (pcc)</th> <th colspan="3">80%</th> <th colspan="3">70%</th> <th colspan="3">50%</th> </tr> <tr> <th>70</th> <th>50</th> <th>30</th> <th>70</th> <th>50</th> <th>30</th> <th>50</th> <th>30</th> </tr> </thead> <tbody> <tr> <td>RCR</td> <td colspan="9">Zonal cavity method - Effective floor reflectance = 20%</td> </tr> <tr><td>0</td><td>118</td><td>118</td><td>118</td><td>115</td><td>115</td><td>115</td><td>111</td><td>111</td></tr> <tr><td>1</td><td>108</td><td>104</td><td>98</td><td>106</td><td>101</td><td>96</td><td>96</td><td>93</td></tr> <tr><td>2</td><td>97</td><td>90</td><td>82</td><td>95</td><td>88</td><td>81</td><td>84</td><td>79</td></tr> <tr><td>3</td><td>90</td><td>79</td><td>70</td><td>86</td><td>77</td><td>69</td><td>73</td><td>68</td></tr> <tr><td>4</td><td>81</td><td>69</td><td>60</td><td>80</td><td>68</td><td>59</td><td>66</td><td>58</td></tr> <tr><td>5</td><td>75</td><td>61</td><td>53</td><td>72</td><td>60</td><td>53</td><td>58</td><td>51</td></tr> <tr><td>6</td><td>69</td><td>56</td><td>46</td><td>68</td><td>55</td><td>46</td><td>53</td><td>46</td></tr> <tr><td>7</td><td>64</td><td>51</td><td>41</td><td>63</td><td>50</td><td>41</td><td>47</td><td>40</td></tr> <tr><td>8</td><td>59</td><td>46</td><td>38</td><td>57</td><td>46</td><td>36</td><td>44</td><td>36</td></tr> <tr><td>9</td><td>56</td><td>41</td><td>34</td><td>55</td><td>41</td><td>34</td><td>40</td><td>33</td></tr> <tr><td>10</td><td>52</td><td>39</td><td>30</td><td>51</td><td>39</td><td>30</td><td>38</td><td>30</td></tr> </tbody> </table>	Ceiling (pcc)	80%			70%			50%			70	50	30	70	50	30	50	30	RCR	Zonal cavity method - Effective floor reflectance = 20%									0	118	118	118	115	115	115	111	111	1	108	104	98	106	101	96	96	93	2	97	90	82	95	88	81	84	79	3	90	79	70	86	77	69	73	68	4	81	69	60	80	68	59	66	58	5	75	61	53	72	60	53	58	51	6	69	56	46	68	55	46	53	46	7	64	51	41	63	50	41	47	40	8	59	46	38	57	46	36	44	36	9	56	41	34	55	41	34	40	33	10	52	39	30	51	39	30	38	30
Ceiling (pcc)	80%					70%			50%																																																																																																																										
	70	50	30	70	50	30	50	30																																																																																																																											
RCR	Zonal cavity method - Effective floor reflectance = 20%																																																																																																																																		
0	118	118	118	115	115	115	111	111																																																																																																																											
1	108	104	98	106	101	96	96	93																																																																																																																											
2	97	90	82	95	88	81	84	79																																																																																																																											
3	90	79	70	86	77	69	73	68																																																																																																																											
4	81	69	60	80	68	59	66	58																																																																																																																											
5	75	61	53	72	60	53	58	51																																																																																																																											
6	69	56	46	68	55	46	53	46																																																																																																																											
7	64	51	41	63	50	41	47	40																																																																																																																											
8	59	46	38	57	46	36	44	36																																																																																																																											
9	56	41	34	55	41	34	40	33																																																																																																																											
10	52	39	30	51	39	30	38	30																																																																																																																											

DLG DuaLED Recessed

1'x4', 2'x2', & 2'x4'

2x2 DuaLED, 4000 nominal delivered lumens

LER – 118

Catalog No.	2DLG40B840-2-D-UNV
Test No.	37668
S/MH	1.2
Lamp Type	LED
Lumens/Lamp	4010
Input Watts	34

Comparative yearly lighting energy cost per 1000 lumens – **\$2.03** based on 3000 hrs. and \$.08 pwr KWH.

The photometric results were obtained in the Day-Brite laboratory which is NVLAP accredited by the National Institute of Standards and Technology.

Photometric values based on test performed in compliance with LM-79.

Vertical Angle	Horizontal Angle			
	0°	45°	90°	-45°
0	1413	1413	1413	1413
5	1407	1405	1407	1405
15	1352	1352	1357	1352
25	1249	1250	1258	1250
35	1095	1104	1119	1104
45	914	930	949	930
55	710	732	747	732
65	491	512	519	512
75	257	262	264	262
85	74	71	74	71

Degrees	Lumens	%
		Luminaire
0-30	1092	27.2
0-40	1784	44.5
0-60	3154	78.7
0-90	4009	100.0

Average Luminance			
Angle	End	45°	Cross
45	4692	4777	4872
55	4493	4634	4732
65	4216	4400	4461
75	3606	3673	3704
85	3079	2967	3067

Coefficients of Utilization

EFFECTIVE FLOOR CAVITY REFLECTANCE 20 PER (pfc=0.20)

Ceiling (pcc)	80%			70%			50%		
	70	50	30	70	50	30	50	30	
Wall (pw)	70	50	30	70	50	30	50	30	
RCR	Zonal cavity method - Effective floor reflectance = 20%								
Room Cavity Ratio	0	118	118	118	115	115	115	111	111
	1	109	104	98	106	102	97	96	93
	2	98	90	82	95	88	81	84	80
	3	90	79	70	86	78	69	75	68
	4	81	69	60	80	68	60	66	58
	5	76	63	54	73	61	53	58	52
	6	69	56	46	68	55	46	54	46
	7	65	51	41	63	50	41	48	40
	8	59	46	38	58	46	38	45	36
	9	56	42	34	55	41	34	40	34
	10	53	39	32	51	39	30	38	30

2x2 DuaLED, 3400 nominal delivered lumens

LER – 117

Catalog No.	2DLG34L840-2-D-UNV-DIM
Test No.	35427
S/MH	1.3
Lamp Type	LED
Lumens/Lamp	3450
Input Watts	29.3

Comparative yearly lighting energy cost per 1000 lumens – **\$2.03** based on 3000 hrs. and \$.08 pwr KWH.

The photometric results were obtained in the Day-Brite laboratory which is NVLAP accredited by the National Institute of Standards and Technology.

Photometric values based on test performed in compliance with LM-79.

Vertical Angle	Horizontal Angle			
	0°	45°	90°	-45°
0	1186	1186	1186	1186
5	1182	1181	1182	1181
15	1145	1143	1147	1143
25	1058	1062	1069	1062
35	935	945	958	945
45	784	799	813	799
55	609	628	641	628
65	421	439	442	439
75	236	238	238	238
85	68	63	65	63

Degrees	Lumens	%
		Luminaire
0-30	925	26.8
0-40	1516	43.9
0-60	2692	78.0
0-90	3451	100.0

Average Luminance			
Angle	End	45°	Cross
45	4024	4101	4177
55	3856	3977	4058
65	3620	3774	3802
75	3309	3344	3337
85	2842	2621	2725

Coefficients of Utilization

EFFECTIVE FLOOR CAVITY REFLECTANCE 20 PER (pfc=0.20)

Ceiling (pcc)	80%			70%			50%		
	70	50	30	70	50	30	50	30	
Wall (pw)	70	50	30	70	50	30	50	30	
RCR	Zonal cavity method - Effective floor reflectance = 20%								
Room Cavity Ratio	0	118	118	118	115	115	115	111	111
	1	108	104	98	106	101	96	96	93
	2	97	90	82	95	88	81	84	79
	3	90	79	70	86	77	69	73	68
	4	81	69	60	80	68	59	66	58
	5	75	61	53	72	60	53	58	52
	6	69	56	46	68	55	46	53	46
	7	64	51	41	63	50	41	47	40
	8	59	46	38	57	46	36	44	36
	9	56	42	34	55	41	34	40	33
	10	53	39	30	51	39	30	38	30

DLG DuaLED Recessed

1'x4', 2'x2', & 2'x4'

2x2 DuaLED, 3800 nominal delivered lumens

LER - 117

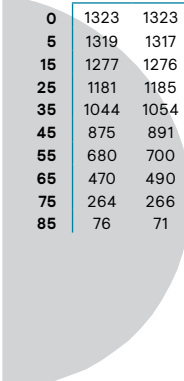
Catalog No. 2DLG38L840-2-D-UNV-DIM Test No. 35428 S/MH 1.3 Lamp Type LED Lumens/Lamp 3849 Input Watts 32.9 Comparative yearly lighting energy cost per 1000 lumens - \$2.05 based on 3000 hrs. and \$.08 pwr KWH. The photometric results were obtained in the Day-Brite laboratory which is NVLAP accredited by the National Institute of Standards and Technology. Photometric values based on test performed in compliance with LM-79.	Candela distribution  <table border="1"> <thead> <tr> <th rowspan="2">Vertical Angle</th> <th colspan="4">Horizontal Angle</th> </tr> <tr> <th>0°</th> <th>45°</th> <th>90°</th> <th>-45°</th> </tr> </thead> <tbody> <tr><td>0</td><td>1323</td><td>1323</td><td>1323</td><td>1323</td></tr> <tr><td>5</td><td>1319</td><td>1317</td><td>1319</td><td>1317</td></tr> <tr><td>15</td><td>1277</td><td>1276</td><td>1279</td><td>1276</td></tr> <tr><td>25</td><td>1181</td><td>1185</td><td>1192</td><td>1185</td></tr> <tr><td>35</td><td>1044</td><td>1054</td><td>1068</td><td>1054</td></tr> <tr><td>45</td><td>875</td><td>891</td><td>907</td><td>891</td></tr> <tr><td>55</td><td>680</td><td>700</td><td>716</td><td>700</td></tr> <tr><td>65</td><td>470</td><td>490</td><td>495</td><td>490</td></tr> <tr><td>75</td><td>264</td><td>266</td><td>267</td><td>266</td></tr> <tr><td>85</td><td>76</td><td>71</td><td>73</td><td>71</td></tr> </tbody> </table>	Vertical Angle	Horizontal Angle				0°	45°	90°	-45°	0	1323	1323	1323	1323	5	1319	1317	1319	1317	15	1277	1276	1279	1276	25	1181	1185	1192	1185	35	1044	1054	1068	1054	45	875	891	907	891	55	680	700	716	700	65	470	490	495	490	75	264	266	267	266	85	76	71	73	71	Light Distribution <table border="1"> <thead> <tr> <th>Degrees</th> <th>Lumens</th> <th>% Luminaire</th> </tr> </thead> <tbody> <tr><td>0-30</td><td>1032</td><td>26.8</td></tr> <tr><td>0-40</td><td>1692</td><td>43.9</td></tr> <tr><td>0-60</td><td>3003</td><td>78.0</td></tr> <tr><td>0-90</td><td>3850</td><td>100</td></tr> </tbody> </table>	Degrees	Lumens	% Luminaire	0-30	1032	26.8	0-40	1692	43.9	0-60	3003	78.0	0-90	3850	100	Average Luminance <table border="1"> <thead> <tr> <th>Angle</th> <th>End</th> <th>45°</th> <th>Cross</th> </tr> </thead> <tbody> <tr><td>45</td><td>4492</td><td>4574</td><td>4659</td></tr> <tr><td>55</td><td>4302</td><td>4431</td><td>4532</td></tr> <tr><td>65</td><td>4040</td><td>4206</td><td>4250</td></tr> <tr><td>75</td><td>3699</td><td>3734</td><td>3742</td></tr> <tr><td>85</td><td>3171</td><td>2958</td><td>3054</td></tr> </tbody> </table>	Angle	End	45°	Cross	45	4492	4574	4659	55	4302	4431	4532	65	4040	4206	4250	75	3699	3734	3742	85	3171	2958	3054																																					
	Vertical Angle		Horizontal Angle																																																																																																																																							
0°		45°	90°	-45°																																																																																																																																						
0	1323	1323	1323	1323																																																																																																																																						
5	1319	1317	1319	1317																																																																																																																																						
15	1277	1276	1279	1276																																																																																																																																						
25	1181	1185	1192	1185																																																																																																																																						
35	1044	1054	1068	1054																																																																																																																																						
45	875	891	907	891																																																																																																																																						
55	680	700	716	700																																																																																																																																						
65	470	490	495	490																																																																																																																																						
75	264	266	267	266																																																																																																																																						
85	76	71	73	71																																																																																																																																						
Degrees	Lumens	% Luminaire																																																																																																																																								
0-30	1032	26.8																																																																																																																																								
0-40	1692	43.9																																																																																																																																								
0-60	3003	78.0																																																																																																																																								
0-90	3850	100																																																																																																																																								
Angle	End	45°	Cross																																																																																																																																							
45	4492	4574	4659																																																																																																																																							
55	4302	4431	4532																																																																																																																																							
65	4040	4206	4250																																																																																																																																							
75	3699	3734	3742																																																																																																																																							
85	3171	2958	3054																																																																																																																																							
	Coefficients of Utilization EFFECTIVE FLOOR CAVITY REFLECTANCE 20 PER (pfc=0.20)	<table border="1"> <thead> <tr> <th rowspan="2">Ceiling (pcc)</th> <th colspan="3">80%</th> <th colspan="3">70%</th> <th colspan="3">50%</th> </tr> <tr> <th>70</th> <th>50</th> <th>30</th> <th>70</th> <th>50</th> <th>30</th> <th>50</th> <th>30</th> </tr> </thead> <tbody> <tr> <td>Wall (pw)</td> <td>70</td> <td>50</td> <td>30</td> <td>70</td> <td>50</td> <td>30</td> <td>50</td> <td>30</td> </tr> <tr> <td>RCR</td> <td colspan="9">Zonal cavity method - Effective floor reflectance = 20%</td> </tr> <tr> <td rowspan="11">Room Cavity Ratio</td> <td>0</td> <td>118</td> <td>118</td> <td>118</td> <td>115</td> <td>115</td> <td>111</td> <td>111</td> </tr> <tr><td>1</td><td>108</td><td>104</td><td>98</td><td>106</td><td>101</td><td>96</td><td>96</td><td>93</td></tr> <tr><td>2</td><td>97</td><td>90</td><td>82</td><td>95</td><td>88</td><td>81</td><td>84</td><td>79</td></tr> <tr><td>3</td><td>90</td><td>79</td><td>70</td><td>86</td><td>77</td><td>69</td><td>73</td><td>68</td></tr> <tr><td>4</td><td>81</td><td>69</td><td>60</td><td>80</td><td>68</td><td>59</td><td>66</td><td>58</td></tr> <tr><td>5</td><td>75</td><td>61</td><td>53</td><td>72</td><td>60</td><td>53</td><td>58</td><td>52</td></tr> <tr><td>6</td><td>69</td><td>56</td><td>46</td><td>68</td><td>55</td><td>46</td><td>53</td><td>46</td></tr> <tr><td>7</td><td>64</td><td>51</td><td>41</td><td>63</td><td>50</td><td>41</td><td>47</td><td>40</td></tr> <tr><td>8</td><td>59</td><td>46</td><td>38</td><td>57</td><td>46</td><td>36</td><td>44</td><td>36</td></tr> <tr><td>9</td><td>56</td><td>42</td><td>34</td><td>55</td><td>41</td><td>34</td><td>40</td><td>33</td></tr> <tr><td>10</td><td>53</td><td>39</td><td>30</td><td>51</td><td>39</td><td>30</td><td>38</td><td>30</td></tr> </tbody> </table>	Ceiling (pcc)	80%			70%			50%			70	50	30	70	50	30	50	30	Wall (pw)	70	50	30	70	50	30	50	30	RCR	Zonal cavity method - Effective floor reflectance = 20%									Room Cavity Ratio	0	118	118	118	115	115	111	111	1	108	104	98	106	101	96	96	93	2	97	90	82	95	88	81	84	79	3	90	79	70	86	77	69	73	68	4	81	69	60	80	68	59	66	58	5	75	61	53	72	60	53	58	52	6	69	56	46	68	55	46	53	46	7	64	51	41	63	50	41	47	40	8	59	46	38	57	46	36	44	36	9	56	42	34	55	41	34	40	33	10	53	39	30	51	39	30	38	30
Ceiling (pcc)	80%			70%			50%																																																																																																																																			
	70	50	30	70	50	30	50	30																																																																																																																																		
Wall (pw)	70	50	30	70	50	30	50	30																																																																																																																																		
RCR	Zonal cavity method - Effective floor reflectance = 20%																																																																																																																																									
Room Cavity Ratio	0	118	118	118	115	115	111	111																																																																																																																																		
	1	108	104	98	106	101	96	96	93																																																																																																																																	
	2	97	90	82	95	88	81	84	79																																																																																																																																	
	3	90	79	70	86	77	69	73	68																																																																																																																																	
	4	81	69	60	80	68	59	66	58																																																																																																																																	
	5	75	61	53	72	60	53	58	52																																																																																																																																	
	6	69	56	46	68	55	46	53	46																																																																																																																																	
	7	64	51	41	63	50	41	47	40																																																																																																																																	
	8	59	46	38	57	46	36	44	36																																																																																																																																	
	9	56	42	34	55	41	34	40	33																																																																																																																																	
	10	53	39	30	51	39	30	38	30																																																																																																																																	

2x2 DuaLED, 4400 nominal delivered lumens

LER - 114

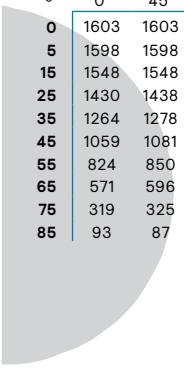
Catalog No. 2DLG44L840-2-D-UNV-DIM Test No. 35429 S/MH 1.3 Lamp Type LED Lumens/Lamp 4670 Input Watts 40.9 Comparative yearly lighting energy cost per 1000 lumens - \$2.07 based on 3000 hrs. and \$.08 pwr KWH. The photometric results were obtained in the Day-Brite laboratory which is NVLAP accredited by the National Institute of Standards and Technology. Photometric values based on test performed in compliance with LM-79.	Candela distribution  <table border="1"> <thead> <tr> <th rowspan="2">Vertical Angle</th> <th colspan="4">Horizontal Angle</th> </tr> <tr> <th>0°</th> <th>45°</th> <th>90°</th> <th>-45°</th> </tr> </thead> <tbody> <tr><td>0</td><td>1603</td><td>1603</td><td>1603</td><td>1603</td></tr> <tr><td>5</td><td>1598</td><td>1598</td><td>1600</td><td>1598</td></tr> <tr><td>15</td><td>1548</td><td>1548</td><td>1553</td><td>1548</td></tr> <tr><td>25</td><td>1430</td><td>1438</td><td>1447</td><td>1438</td></tr> <tr><td>35</td><td>1264</td><td>1278</td><td>1296</td><td>1278</td></tr> <tr><td>45</td><td>1059</td><td>1081</td><td>1101</td><td>1081</td></tr> <tr><td>55</td><td>824</td><td>850</td><td>870</td><td>850</td></tr> <tr><td>65</td><td>571</td><td>596</td><td>601</td><td>596</td></tr> <tr><td>75</td><td>319</td><td>325</td><td>324</td><td>325</td></tr> <tr><td>85</td><td>93</td><td>87</td><td>90</td><td>87</td></tr> </tbody> </table>	Vertical Angle	Horizontal Angle				0°	45°	90°	-45°	0	1603	1603	1603	1603	5	1598	1598	1600	1598	15	1548	1548	1553	1548	25	1430	1438	1447	1438	35	1264	1278	1296	1278	45	1059	1081	1101	1081	55	824	850	870	850	65	571	596	601	596	75	319	325	324	325	85	93	87	90	87	Light Distribution <table border="1"> <thead> <tr> <th>Degrees</th> <th>Lumens</th> <th>% Luminaire</th> </tr> </thead> <tbody> <tr><td>0-30</td><td>1252</td><td>26.8</td></tr> <tr><td>0-40</td><td>2052</td><td>44.0</td></tr> <tr><td>0-60</td><td>3641</td><td>78.0</td></tr> <tr><td>0-90</td><td>4668</td><td>100.0</td></tr> </tbody> </table>	Degrees	Lumens	% Luminaire	0-30	1252	26.8	0-40	2052	44.0	0-60	3641	78.0	0-90	4668	100.0	Average Luminance <table border="1"> <thead> <tr> <th>Angle</th> <th>End</th> <th>45°</th> <th>Cross</th> </tr> </thead> <tbody> <tr><td>45</td><td>5436</td><td>5546</td><td>5651</td></tr> <tr><td>55</td><td>5212</td><td>5377</td><td>5500</td></tr> <tr><td>65</td><td>4901</td><td>5113</td><td>5161</td></tr> <tr><td>75</td><td>4475</td><td>4553</td><td>4535</td></tr> <tr><td>85</td><td>3880</td><td>3618</td><td>3730</td></tr> </tbody> </table>	Angle	End	45°	Cross	45	5436	5546	5651	55	5212	5377	5500	65	4901	5113	5161	75	4475	4553	4535	85	3880	3618	3730																																					
	Vertical Angle		Horizontal Angle																																																																																																																																							
0°		45°	90°	-45°																																																																																																																																						
0	1603	1603	1603	1603																																																																																																																																						
5	1598	1598	1600	1598																																																																																																																																						
15	1548	1548	1553	1548																																																																																																																																						
25	1430	1438	1447	1438																																																																																																																																						
35	1264	1278	1296	1278																																																																																																																																						
45	1059	1081	1101	1081																																																																																																																																						
55	824	850	870	850																																																																																																																																						
65	571	596	601	596																																																																																																																																						
75	319	325	324	325																																																																																																																																						
85	93	87	90	87																																																																																																																																						
Degrees	Lumens	% Luminaire																																																																																																																																								
0-30	1252	26.8																																																																																																																																								
0-40	2052	44.0																																																																																																																																								
0-60	3641	78.0																																																																																																																																								
0-90	4668	100.0																																																																																																																																								
Angle	End	45°	Cross																																																																																																																																							
45	5436	5546	5651																																																																																																																																							
55	5212	5377	5500																																																																																																																																							
65	4901	5113	5161																																																																																																																																							
75	4475	4553	4535																																																																																																																																							
85	3880	3618	3730																																																																																																																																							
	Coefficients of Utilization EFFECTIVE FLOOR CAVITY REFLECTANCE 20 PER (pfc=0.20)	<table border="1"> <thead> <tr> <th rowspan="2">Ceiling (pcc)</th> <th colspan="3">80%</th> <th colspan="3">70%</th> <th colspan="3">50%</th> </tr> <tr> <th>70</th> <th>50</th> <th>30</th> <th>70</th> <th>50</th> <th>30</th> <th>50</th> <th>30</th> </tr> </thead> <tbody> <tr> <td>Wall (pw)</td> <td>70</td> <td>50</td> <td>30</td> <td>70</td> <td>50</td> <td>30</td> <td>50</td> <td>30</td> </tr> <tr> <td>RCR</td> <td colspan="9">Zonal cavity method - Effective floor reflectance = 20%</td> </tr> <tr> <td rowspan="11">Room Cavity Ratio</td> <td>0</td> <td>119</td> <td>119</td> <td>119</td> <td>116</td> <td>116</td> <td>111</td> <td>111</td> </tr> <tr><td>1</td><td>108</td><td>104</td><td>99</td><td>106</td><td>101</td><td>97</td><td>97</td><td>94</td></tr> <tr><td>2</td><td>98</td><td>90</td><td>83</td><td>96</td><td>88</td><td>82</td><td>85</td><td>79</td></tr> <tr><td>3</td><td>90</td><td>79</td><td>71</td><td>87</td><td>77</td><td>70</td><td>74</td><td>68</td></tr> <tr><td>4</td><td>82</td><td>70</td><td>61</td><td>80</td><td>69</td><td>60</td><td>66</td><td>59</td></tr> <tr><td>5</td><td>75</td><td>62</td><td>53</td><td>73</td><td>61</td><td>53</td><td>59</td><td>52</td></tr> <tr><td>6</td><td>70</td><td>56</td><td>47</td><td>68</td><td>55</td><td>47</td><td>53</td><td>46</td></tr> <tr><td>7</td><td>64</td><td>51</td><td>42</td><td>63</td><td>50</td><td>42</td><td>48</td><td>41</td></tr> <tr><td>8</td><td>60</td><td>46</td><td>38</td><td>58</td><td>46</td><td>37</td><td>44</td><td>37</td></tr> <tr><td>9</td><td>56</td><td>43</td><td>34</td><td>55</td><td>42</td><td>34</td><td>41</td><td>33</td></tr> <tr><td>10</td><td>53</td><td>39</td><td>31</td><td>51</td><td>39</td><td>31</td><td>38</td><td>31</td></tr> </tbody> </table>	Ceiling (pcc)	80%			70%			50%			70	50	30	70	50	30	50	30	Wall (pw)	70	50	30	70	50	30	50	30	RCR	Zonal cavity method - Effective floor reflectance = 20%									Room Cavity Ratio	0	119	119	119	116	116	111	111	1	108	104	99	106	101	97	97	94	2	98	90	83	96	88	82	85	79	3	90	79	71	87	77	70	74	68	4	82	70	61	80	69	60	66	59	5	75	62	53	73	61	53	59	52	6	70	56	47	68	55	47	53	46	7	64	51	42	63	50	42	48	41	8	60	46	38	58	46	37	44	37	9	56	43	34	55	42	34	41	33	10	53	39	31	51	39	31	38	31
Ceiling (pcc)	80%			70%			50%																																																																																																																																			
	70	50	30	70	50	30	50	30																																																																																																																																		
Wall (pw)	70	50	30	70	50	30	50	30																																																																																																																																		
RCR	Zonal cavity method - Effective floor reflectance = 20%																																																																																																																																									
Room Cavity Ratio	0	119	119	119	116	116	111	111																																																																																																																																		
	1	108	104	99	106	101	97	97	94																																																																																																																																	
	2	98	90	83	96	88	82	85	79																																																																																																																																	
	3	90	79	71	87	77	70	74	68																																																																																																																																	
	4	82	70	61	80	69	60	66	59																																																																																																																																	
	5	75	62	53	73	61	53	59	52																																																																																																																																	
	6	70	56	47	68	55	47	53	46																																																																																																																																	
	7	64	51	42	63	50	42	48	41																																																																																																																																	
	8	60	46	38	58	46	37	44	37																																																																																																																																	
	9	56	43	34	55	42	34	41	33																																																																																																																																	
	10	53	39	31	51	39	31	38	31																																																																																																																																	

DLG DuaLED Recessed

1'x4', 2'x2', & 2'x4'

2x4 DuaLED, 4200 nominal delivered lumens

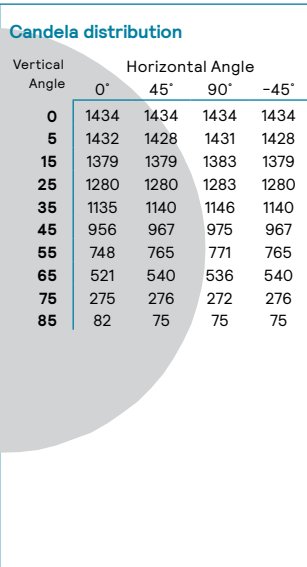
Catalog No. 2DLG42B840-4-D-UNV Test No. 37667 S/MH 1.3 Lamp Type LED Lumens/Lamp 4161 Input Watts 33 Comparative yearly lighting energy cost per 1000 lumens – \$1.88 based on 3000 hrs. and \$.08 pwr KWH. The photometric results were obtained in the Day-Brite laboratory which is NVLAP accredited by the National Institute of Standards and Technology. Photometric values based on test performed in compliance with LM-79.	Candela distribution  <table border="1"> <thead> <tr> <th rowspan="2">Vertical Angle</th> <th colspan="4">Horizontal Angle</th> </tr> <tr> <th>0°</th> <th>45°</th> <th>90°</th> <th>-45°</th> </tr> </thead> <tbody> <tr><td>0</td><td>1434</td><td>1434</td><td>1434</td><td>1434</td></tr> <tr><td>5</td><td>1432</td><td>1428</td><td>1431</td><td>1428</td></tr> <tr><td>15</td><td>1379</td><td>1379</td><td>1383</td><td>1379</td></tr> <tr><td>25</td><td>1280</td><td>1280</td><td>1283</td><td>1280</td></tr> <tr><td>35</td><td>1135</td><td>1140</td><td>1146</td><td>1140</td></tr> <tr><td>45</td><td>956</td><td>967</td><td>975</td><td>967</td></tr> <tr><td>55</td><td>748</td><td>765</td><td>771</td><td>765</td></tr> <tr><td>65</td><td>521</td><td>540</td><td>536</td><td>540</td></tr> <tr><td>75</td><td>275</td><td>276</td><td>272</td><td>276</td></tr> <tr><td>85</td><td>82</td><td>75</td><td>75</td><td>75</td></tr> </tbody> </table>	Vertical Angle	Horizontal Angle				0°	45°	90°	-45°	0	1434	1434	1434	1434	5	1432	1428	1431	1428	15	1379	1379	1383	1379	25	1280	1280	1283	1280	35	1135	1140	1146	1140	45	956	967	975	967	55	748	765	771	765	65	521	540	536	540	75	275	276	272	276	85	82	75	75	75	Light Distribution <table border="1"> <thead> <tr> <th>Degrees</th> <th>Lumens</th> <th>% Luminaire</th> </tr> </thead> <tbody> <tr><td>0-30</td><td>1114</td><td>26.8</td></tr> <tr><td>0-40</td><td>1827</td><td>43.9</td></tr> <tr><td>0-60</td><td>3253</td><td>78.2</td></tr> <tr><td>0-90</td><td>4161</td><td>100.0</td></tr> </tbody> </table>	Degrees	Lumens	% Luminaire	0-30	1114	26.8	0-40	1827	43.9	0-60	3253	78.2	0-90	4161	100.0	Average Luminance <table border="1"> <thead> <tr> <th>Angle</th> <th>End</th> <th>45°</th> <th>Cross</th> </tr> </thead> <tbody> <tr><td>45</td><td>1965</td><td>1986</td><td>2002</td></tr> <tr><td>55</td><td>1893</td><td>1937</td><td>1953</td></tr> <tr><td>65</td><td>1790</td><td>1855</td><td>1841</td></tr> <tr><td>75</td><td>1543</td><td>1550</td><td>1526</td></tr> <tr><td>85</td><td>1367</td><td>1248</td><td>1245</td></tr> </tbody> </table>	Angle	End	45°	Cross	45	1965	1986	2002	55	1893	1937	1953	65	1790	1855	1841	75	1543	1550	1526	85	1367	1248	1245																																						
	Vertical Angle		Horizontal Angle																																																																																																																																								
0°		45°	90°	-45°																																																																																																																																							
0	1434	1434	1434	1434																																																																																																																																							
5	1432	1428	1431	1428																																																																																																																																							
15	1379	1379	1383	1379																																																																																																																																							
25	1280	1280	1283	1280																																																																																																																																							
35	1135	1140	1146	1140																																																																																																																																							
45	956	967	975	967																																																																																																																																							
55	748	765	771	765																																																																																																																																							
65	521	540	536	540																																																																																																																																							
75	275	276	272	276																																																																																																																																							
85	82	75	75	75																																																																																																																																							
Degrees	Lumens	% Luminaire																																																																																																																																									
0-30	1114	26.8																																																																																																																																									
0-40	1827	43.9																																																																																																																																									
0-60	3253	78.2																																																																																																																																									
0-90	4161	100.0																																																																																																																																									
Angle	End	45°	Cross																																																																																																																																								
45	1965	1986	2002																																																																																																																																								
55	1893	1937	1953																																																																																																																																								
65	1790	1855	1841																																																																																																																																								
75	1543	1550	1526																																																																																																																																								
85	1367	1248	1245																																																																																																																																								
		Coefficients of Utilization EFFECTIVE FLOOR CAVITY REFLECTANCE 20 PER (pfc=0.20) <table border="1"> <thead> <tr> <th rowspan="2">Ceiling (pcc)</th> <th colspan="3">80%</th> <th colspan="3">70%</th> <th colspan="3">50%</th> </tr> <tr> <th>70</th> <th>50</th> <th>30</th> <th>70</th> <th>50</th> <th>30</th> <th>50</th> <th>30</th> </tr> </thead> <tbody> <tr> <td>Wall (pw)</td> <td>70</td> <td>50</td> <td>30</td> <td>70</td> <td>50</td> <td>30</td> <td>50</td> <td>30</td> </tr> <tr> <td>RCR</td> <td colspan="9">Zonal cavity method - Effective floor reflectance = 20%</td> </tr> <tr> <td>Room Cavity Ratio</td> <td>0</td><td>118</td><td>118</td><td>118</td><td>115</td><td>115</td><td>115</td><td>111</td><td>111</td></tr> <tr><td>1</td><td>109</td><td>104</td><td>98</td><td>106</td><td>101</td><td>96</td><td>96</td><td>93</td></tr> <tr><td>2</td><td>98</td><td>90</td><td>82</td><td>95</td><td>88</td><td>81</td><td>84</td><td>79</td></tr> <tr><td>3</td><td>90</td><td>79</td><td>70</td><td>86</td><td>77</td><td>69</td><td>73</td><td>68</td></tr> <tr><td>4</td><td>81</td><td>69</td><td>60</td><td>80</td><td>68</td><td>59</td><td>66</td><td>58</td></tr> <tr><td>5</td><td>75</td><td>61</td><td>53</td><td>72</td><td>60</td><td>53</td><td>58</td><td>52</td></tr> <tr><td>6</td><td>69</td><td>56</td><td>46</td><td>68</td><td>55</td><td>46</td><td>53</td><td>46</td></tr> <tr><td>7</td><td>64</td><td>51</td><td>41</td><td>63</td><td>50</td><td>41</td><td>47</td><td>40</td></tr> <tr><td>8</td><td>59</td><td>46</td><td>38</td><td>57</td><td>46</td><td>36</td><td>44</td><td>36</td></tr> <tr><td>9</td><td>56</td><td>42</td><td>34</td><td>55</td><td>41</td><td>34</td><td>40</td><td>33</td></tr> <tr><td>10</td><td>53</td><td>39</td><td>30</td><td>51</td><td>39</td><td>30</td><td>38</td><td>30</td></tr> </tbody> </table>	Ceiling (pcc)	80%			70%			50%			70	50	30	70	50	30	50	30	Wall (pw)	70	50	30	70	50	30	50	30	RCR	Zonal cavity method - Effective floor reflectance = 20%									Room Cavity Ratio	0	118	118	118	115	115	115	111	111	1	109	104	98	106	101	96	96	93	2	98	90	82	95	88	81	84	79	3	90	79	70	86	77	69	73	68	4	81	69	60	80	68	59	66	58	5	75	61	53	72	60	53	58	52	6	69	56	46	68	55	46	53	46	7	64	51	41	63	50	41	47	40	8	59	46	38	57	46	36	44	36	9	56	42	34	55	41	34	40	33	10	53	39	30	51	39	30	38	30
Ceiling (pcc)	80%			70%			50%																																																																																																																																				
	70	50	30	70	50	30	50	30																																																																																																																																			
Wall (pw)	70	50	30	70	50	30	50	30																																																																																																																																			
RCR	Zonal cavity method - Effective floor reflectance = 20%																																																																																																																																										
Room Cavity Ratio	0	118	118	118	115	115	115	111	111																																																																																																																																		
1	109	104	98	106	101	96	96	93																																																																																																																																			
2	98	90	82	95	88	81	84	79																																																																																																																																			
3	90	79	70	86	77	69	73	68																																																																																																																																			
4	81	69	60	80	68	59	66	58																																																																																																																																			
5	75	61	53	72	60	53	58	52																																																																																																																																			
6	69	56	46	68	55	46	53	46																																																																																																																																			
7	64	51	41	63	50	41	47	40																																																																																																																																			
8	59	46	38	57	46	36	44	36																																																																																																																																			
9	56	42	34	55	41	34	40	33																																																																																																																																			
10	53	39	30	51	39	30	38	30																																																																																																																																			

2x4 DuaLED, 4300 nominal delivered lumens

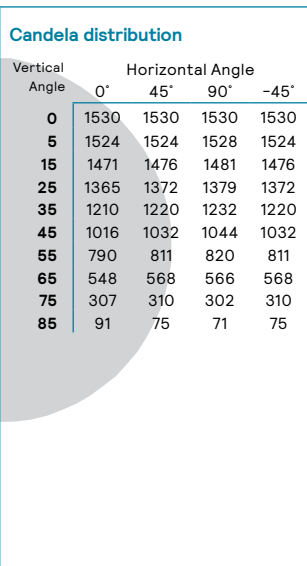
Catalog No. 2DLG43L840-4-D Test No. 36164 S/MH 1.3 Lamp Type LED Lumens/Lamp 4445 Input Watts 34.1 Comparative yearly lighting energy cost per 1000 lumens – \$1.85 based on 3000 hrs. and \$.08 pwr KWH. The photometric results were obtained in the Day-Brite laboratory which is NVLAP accredited by the National Institute of Standards and Technology. Photometric values based on test performed in compliance with LM-79.	Candela distribution  <table border="1"> <thead> <tr> <th rowspan="2">Vertical Angle</th> <th colspan="4">Horizontal Angle</th> </tr> <tr> <th>0°</th> <th>45°</th> <th>90°</th> <th>-45°</th> </tr> </thead> <tbody> <tr><td>0</td><td>1530</td><td>1530</td><td>1530</td><td>1530</td></tr> <tr><td>5</td><td>1524</td><td>1524</td><td>1528</td><td>1524</td></tr> <tr><td>15</td><td>1471</td><td>1476</td><td>1481</td><td>1476</td></tr> <tr><td>25</td><td>1365</td><td>1372</td><td>1379</td><td>1372</td></tr> <tr><td>35</td><td>1210</td><td>1220</td><td>1232</td><td>1220</td></tr> <tr><td>45</td><td>1016</td><td>1032</td><td>1044</td><td>1032</td></tr> <tr><td>55</td><td>790</td><td>811</td><td>820</td><td>811</td></tr> <tr><td>65</td><td>548</td><td>568</td><td>566</td><td>568</td></tr> <tr><td>75</td><td>307</td><td>310</td><td>302</td><td>310</td></tr> <tr><td>85</td><td>91</td><td>75</td><td>71</td><td>75</td></tr> </tbody> </table>	Vertical Angle	Horizontal Angle				0°	45°	90°	-45°	0	1530	1530	1530	1530	5	1524	1524	1528	1524	15	1471	1476	1481	1476	25	1365	1372	1379	1372	35	1210	1220	1232	1220	45	1016	1032	1044	1032	55	790	811	820	811	65	548	568	566	568	75	307	310	302	310	85	91	75	71	75	Light Distribution <table border="1"> <thead> <tr> <th>Degrees</th> <th>Lumens</th> <th>% Luminaire</th> </tr> </thead> <tbody> <tr><td>0-30</td><td>1193</td><td>26.8</td></tr> <tr><td>0-40</td><td>1956</td><td>44.0</td></tr> <tr><td>0-60</td><td>3472</td><td>78.1</td></tr> <tr><td>0-90</td><td>4445</td><td>100.0</td></tr> </tbody> </table>	Degrees	Lumens	% Luminaire	0-30	1193	26.8	0-40	1956	44.0	0-60	3472	78.1	0-90	4445	100.0	Average Luminance <table border="1"> <thead> <tr> <th>Angle</th> <th>End</th> <th>45°</th> <th>Cross</th> </tr> </thead> <tbody> <tr><td>45</td><td>2679</td><td>2721</td><td>2752</td></tr> <tr><td>55</td><td>2569</td><td>2636</td><td>2666</td></tr> <tr><td>65</td><td>2418</td><td>2508</td><td>2497</td></tr> <tr><td>75</td><td>2213</td><td>2235</td><td>2176</td></tr> <tr><td>85</td><td>1945</td><td>1609</td><td>1523</td></tr> </tbody> </table>	Angle	End	45°	Cross	45	2679	2721	2752	55	2569	2636	2666	65	2418	2508	2497	75	2213	2235	2176	85	1945	1609	1523																																						
	Vertical Angle		Horizontal Angle																																																																																																																																								
0°		45°	90°	-45°																																																																																																																																							
0	1530	1530	1530	1530																																																																																																																																							
5	1524	1524	1528	1524																																																																																																																																							
15	1471	1476	1481	1476																																																																																																																																							
25	1365	1372	1379	1372																																																																																																																																							
35	1210	1220	1232	1220																																																																																																																																							
45	1016	1032	1044	1032																																																																																																																																							
55	790	811	820	811																																																																																																																																							
65	548	568	566	568																																																																																																																																							
75	307	310	302	310																																																																																																																																							
85	91	75	71	75																																																																																																																																							
Degrees	Lumens	% Luminaire																																																																																																																																									
0-30	1193	26.8																																																																																																																																									
0-40	1956	44.0																																																																																																																																									
0-60	3472	78.1																																																																																																																																									
0-90	4445	100.0																																																																																																																																									
Angle	End	45°	Cross																																																																																																																																								
45	2679	2721	2752																																																																																																																																								
55	2569	2636	2666																																																																																																																																								
65	2418	2508	2497																																																																																																																																								
75	2213	2235	2176																																																																																																																																								
85	1945	1609	1523																																																																																																																																								
		Coefficients of Utilization EFFECTIVE FLOOR CAVITY REFLECTANCE 20 PER (pfc=0.20) <table border="1"> <thead> <tr> <th rowspan="2">Ceiling (pcc)</th> <th colspan="3">80%</th> <th colspan="3">70%</th> <th colspan="3">50%</th> </tr> <tr> <th>70</th> <th>50</th> <th>30</th> <th>70</th> <th>50</th> <th>30</th> <th>50</th> <th>30</th> </tr> </thead> <tbody> <tr> <td>Wall (pw)</td> <td>70</td> <td>50</td> <td>30</td> <td>70</td> <td>50</td> <td>30</td> <td>50</td> <td>30</td> </tr> <tr> <td>RCR</td> <td colspan="9">Zonal cavity method - Effective floor reflectance = 20%</td> </tr> <tr> <td>Room Cavity Ratio</td> <td>0</td><td>118</td><td>118</td><td>118</td><td>115</td><td>115</td><td>115</td><td>111</td><td>111</td></tr> <tr><td>1</td><td>109</td><td>104</td><td>98</td><td>106</td><td>101</td><td>96</td><td>96</td><td>93</td></tr> <tr><td>2</td><td>98</td><td>90</td><td>82</td><td>95</td><td>88</td><td>81</td><td>84</td><td>79</td></tr> <tr><td>3</td><td>90</td><td>79</td><td>70</td><td>86</td><td>77</td><td>69</td><td>73</td><td>68</td></tr> <tr><td>4</td><td>81</td><td>69</td><td>60</td><td>80</td><td>68</td><td>59</td><td>66</td><td>58</td></tr> <tr><td>5</td><td>75</td><td>61</td><td>53</td><td>72</td><td>60</td><td>53</td><td>58</td><td>52</td></tr> <tr><td>6</td><td>69</td><td>56</td><td>46</td><td>68</td><td>55</td><td>46</td><td>53</td><td>46</td></tr> <tr><td>7</td><td>65</td><td>51</td><td>41</td><td>63</td><td>50</td><td>41</td><td>47</td><td>40</td></tr> <tr><td>8</td><td>59</td><td>46</td><td>38</td><td>57</td><td>46</td><td>36</td><td>44</td><td>36</td></tr> <tr><td>9</td><td>56</td><td>42</td><td>34</td><td>55</td><td>41</td><td>34</td><td>40</td><td>34</td></tr> <tr><td>10</td><td>53</td><td>39</td><td>30</td><td>51</td><td>39</td><td>30</td><td>38</td><td>30</td></tr> </tbody> </table>	Ceiling (pcc)	80%			70%			50%			70	50	30	70	50	30	50	30	Wall (pw)	70	50	30	70	50	30	50	30	RCR	Zonal cavity method - Effective floor reflectance = 20%									Room Cavity Ratio	0	118	118	118	115	115	115	111	111	1	109	104	98	106	101	96	96	93	2	98	90	82	95	88	81	84	79	3	90	79	70	86	77	69	73	68	4	81	69	60	80	68	59	66	58	5	75	61	53	72	60	53	58	52	6	69	56	46	68	55	46	53	46	7	65	51	41	63	50	41	47	40	8	59	46	38	57	46	36	44	36	9	56	42	34	55	41	34	40	34	10	53	39	30	51	39	30	38	30
Ceiling (pcc)	80%			70%			50%																																																																																																																																				
	70	50	30	70	50	30	50	30																																																																																																																																			
Wall (pw)	70	50	30	70	50	30	50	30																																																																																																																																			
RCR	Zonal cavity method - Effective floor reflectance = 20%																																																																																																																																										
Room Cavity Ratio	0	118	118	118	115	115	115	111	111																																																																																																																																		
1	109	104	98	106	101	96	96	93																																																																																																																																			
2	98	90	82	95	88	81	84	79																																																																																																																																			
3	90	79	70	86	77	69	73	68																																																																																																																																			
4	81	69	60	80	68	59	66	58																																																																																																																																			
5	75	61	53	72	60	53	58	52																																																																																																																																			
6	69	56	46	68	55	46	53	46																																																																																																																																			
7	65	51	41	63	50	41	47	40																																																																																																																																			
8	59	46	38	57	46	36	44	36																																																																																																																																			
9	56	42	34	55	41	34	40	34																																																																																																																																			
10	53	39	30	51	39	30	38	30																																																																																																																																			

2x4 DuaLED, 4900 nominal delivered lumens

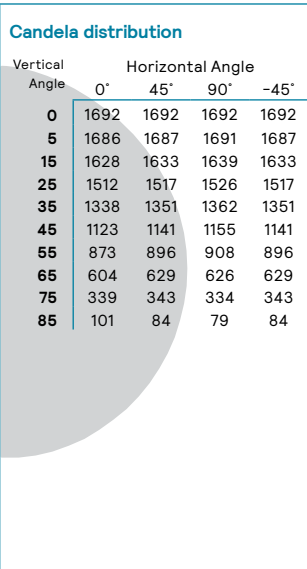
Catalog No. 2DLG49L840-4-D Test No. 36166 S/MH 1.3 Lamp Type LED Lumens/Lamp 4919 Input Watts 37.7 Comparative yearly lighting energy cost per 1000 lumens – \$1.85 based on 3000 hrs. and \$.08 pwr KWH. The photometric results were obtained in the Day-Brite laboratory which is NVLAP accredited by the National Institute of Standards and Technology. Photometric values based on test performed in compliance with LM-79.	Candela distribution  <table border="1"> <thead> <tr> <th rowspan="2">Vertical Angle</th> <th colspan="4">Horizontal Angle</th> </tr> <tr> <th>0°</th> <th>45°</th> <th>90°</th> <th>-45°</th> </tr> </thead> <tbody> <tr><td>0</td><td>1692</td><td>1692</td><td>1692</td><td>1692</td></tr> <tr><td>5</td><td>1686</td><td>1687</td><td>1691</td><td>1687</td></tr> <tr><td>15</td><td>1628</td><td>1633</td><td>1639</td><td>1633</td></tr> <tr><td>25</td><td>1512</td><td>1517</td><td>1526</td><td>1517</td></tr> <tr><td>35</td><td>1338</td><td>1351</td><td>1362</td><td>1351</td></tr> <tr><td>45</td><td>1123</td><td>1141</td><td>1155</td><td>1141</td></tr> <tr><td>55</td><td>873</td><td>896</td><td>908</td><td>896</td></tr> <tr><td>65</td><td>604</td><td>629</td><td>626</td><td>629</td></tr> <tr><td>75</td><td>339</td><td>343</td><td>334</td><td>343</td></tr> <tr><td>85</td><td>101</td><td>84</td><td>79</td><td>84</td></tr> </tbody> </table>	Vertical Angle	Horizontal Angle				0°	45°	90°	-45°	0	1692	1692	1692	1692	5	1686	1687	1691	1687	15	1628	1633	1639	1633	25	1512	1517	1526	1517	35	1338	1351	1362	1351	45	1123	1141	1155	1141	55	873	896	908	896	65	604	629	626	629	75	339	343	334	343	85	101	84	79	84	Light Distribution <table border="1"> <thead> <tr> <th>Degrees</th> <th>Lumens</th> <th>% Luminaire</th> </tr> </thead> <tbody> <tr><td>0-30</td><td>1320</td><td>26.8</td></tr> <tr><td>0-40</td><td>2165</td><td>44.0</td></tr> <tr><td>0-60</td><td>3842</td><td>78.1</td></tr> <tr><td>0-90</td><td>4919</td><td>100.0</td></tr> </tbody> </table>	Degrees	Lumens	% Luminaire	0-30	1320	26.8	0-40	2165	44.0	0-60	3842	78.1	0-90	4919	100.0	Average Luminance <table border="1"> <thead> <tr> <th>Angle</th> <th>End</th> <th>45°</th> <th>Cross</th> </tr> </thead> <tbody> <tr><td>45</td><td>2962</td><td>3010</td><td>3045</td></tr> <tr><td>55</td><td>2838</td><td>2913</td><td>2953</td></tr> <tr><td>65</td><td>2666</td><td>2777</td><td>2763</td></tr> <tr><td>75</td><td>2444</td><td>2474</td><td>2403</td></tr> <tr><td>85</td><td>2155</td><td>1804</td><td>1692</td></tr> </tbody> </table>	Angle	End	45°	Cross	45	2962	3010	3045	55	2838	2913	2953	65	2666	2777	2763	75	2444	2474	2403	85	2155	1804	1692																																						
	Vertical Angle		Horizontal Angle																																																																																																																																								
0°		45°	90°	-45°																																																																																																																																							
0	1692	1692	1692	1692																																																																																																																																							
5	1686	1687	1691	1687																																																																																																																																							
15	1628	1633	1639	1633																																																																																																																																							
25	1512	1517	1526	1517																																																																																																																																							
35	1338	1351	1362	1351																																																																																																																																							
45	1123	1141	1155	1141																																																																																																																																							
55	873	896	908	896																																																																																																																																							
65	604	629	626	629																																																																																																																																							
75	339	343	334	343																																																																																																																																							
85	101	84	79	84																																																																																																																																							
Degrees	Lumens	% Luminaire																																																																																																																																									
0-30	1320	26.8																																																																																																																																									
0-40	2165	44.0																																																																																																																																									
0-60	3842	78.1																																																																																																																																									
0-90	4919	100.0																																																																																																																																									
Angle	End	45°	Cross																																																																																																																																								
45	2962	3010	3045																																																																																																																																								
55	2838	2913	2953																																																																																																																																								
65	2666	2777	2763																																																																																																																																								
75	2444	2474	2403																																																																																																																																								
85	2155	1804	1692																																																																																																																																								
		Coefficients of Utilization EFFECTIVE FLOOR CAVITY REFLECTANCE 20 PER (pfc=0.20) <table border="1"> <thead> <tr> <th rowspan="2">Ceiling (pcc)</th> <th colspan="3">80%</th> <th colspan="3">70%</th> <th colspan="3">50%</th> </tr> <tr> <th>70</th> <th>50</th> <th>30</th> <th>70</th> <th>50</th> <th>30</th> <th>50</th> <th>30</th> </tr> </thead> <tbody> <tr> <td>Wall (pw)</td> <td>70</td> <td>50</td> <td>30</td> <td>70</td> <td>50</td> <td>30</td> <td>50</td> <td>30</td> </tr> <tr> <td>RCR</td> <td colspan="9">Zonal cavity method - Effective floor reflectance = 20%</td> </tr> <tr> <td>Room Cavity Ratio</td> <td>0</td><td>118</td><td>118</td><td>118</td><td>115</td><td>115</td><td>115</td><td>111</td><td>111</td></tr> <tr><td>1</td><td>109</td><td>104</td><td>98</td><td>106</td><td>101</td><td>96</td><td>96</td><td>93</td></tr> <tr><td>2</td><td>98</td><td>90</td><td>82</td><td>95</td><td>88</td><td>81</td><td>84</td><td>79</td></tr> <tr><td>3</td><td>90</td><td>79</td><td>70</td><td>86</td><td>77</td><td>69</td><td>73</td><td>68</td></tr> <tr><td>4</td><td>81</td><td>69</td><td>60</td><td>80</td><td>68</td><td>59</td><td>66</td><td>58</td></tr> <tr><td>5</td><td>75</td><td>61</td><td>53</td><td>72</td><td>60</td><td>53</td><td>58</td><td>52</td></tr> <tr><td>6</td><td>69</td><td>56</td><td>46</td><td>68</td><td>55</td><td>46</td><td>53</td><td>46</td></tr> <tr><td>7</td><td>65</td><td>51</td><td>41</td><td>63</td><td>50</td><td>41</td><td>47</td><td>40</td></tr> <tr><td>8</td><td>59</td><td>46</td><td>38</td><td>57</td><td>46</td><td>36</td><td>44</td><td>36</td></tr> <tr><td>9</td><td>56</td><td>42</td><td>34</td><td>55</td><td>41</td><td>34</td><td>40</td><td>34</td></tr> <tr><td>10</td><td>53</td><td>39</td><td>30</td><td>51</td><td>39</td><td>30</td><td>38</td><td>30</td></tr> </tbody> </table>	Ceiling (pcc)	80%			70%			50%			70	50	30	70	50	30	50	30	Wall (pw)	70	50	30	70	50	30	50	30	RCR	Zonal cavity method - Effective floor reflectance = 20%									Room Cavity Ratio	0	118	118	118	115	115	115	111	111	1	109	104	98	106	101	96	96	93	2	98	90	82	95	88	81	84	79	3	90	79	70	86	77	69	73	68	4	81	69	60	80	68	59	66	58	5	75	61	53	72	60	53	58	52	6	69	56	46	68	55	46	53	46	7	65	51	41	63	50	41	47	40	8	59	46	38	57	46	36	44	36	9	56	42	34	55	41	34	40	34	10	53	39	30	51	39	30	38	30
Ceiling (pcc)	80%			70%			50%																																																																																																																																				
	70	50	30	70	50	30	50	30																																																																																																																																			
Wall (pw)	70	50	30	70	50	30	50	30																																																																																																																																			
RCR	Zonal cavity method - Effective floor reflectance = 20%																																																																																																																																										
Room Cavity Ratio	0	118	118	118	115	115	115	111	111																																																																																																																																		
1	109	104	98	106	101	96	96	93																																																																																																																																			
2	98	90	82	95	88	81	84	79																																																																																																																																			
3	90	79	70	86	77	69	73	68																																																																																																																																			
4	81	69	60	80	68	59	66	58																																																																																																																																			
5	75	61	53	72	60	53	58	52																																																																																																																																			
6	69	56	46	68	55	46	53	46																																																																																																																																			
7	65	51	41	63	50	41	47	40																																																																																																																																			
8	59	46	38	57	46	36	44	36																																																																																																																																			
9	56	42	34	55	41	34	40	34																																																																																																																																			
10	53	39	30	51	39	30	38	30																																																																																																																																			

DLG DuaLED Recessed

1'x4', 2'x2', & 2'x4'

2x4 DuaLED, 5800 nominal delivered lumens

LER - 129

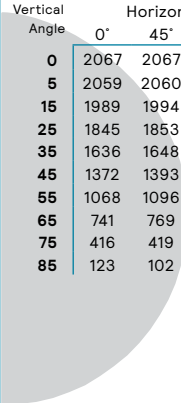
Catalog No. 2DLG58L840-4-D Test No. 36167 S/MH 1.3 Lamp Type LED Lumens/Lamp 6007 Input Watts 46.3 Comparative yearly lighting energy cost per 1000 lumens - \$1.85 based on 3000 hrs. and \$.08 pwr KWH. The photometric results were obtained in the Day-Brite laboratory which is NVLAP accredited by the National Institute of Standards and Technology. Photometric values based on test performed in compliance with LM-79.	Candela distribution  <table border="1"> <thead> <tr> <th rowspan="2">Vertical Angle</th> <th colspan="4">Horizontal Angle</th> </tr> <tr> <th>0°</th> <th>45°</th> <th>90°</th> <th>-45°</th> </tr> </thead> <tbody> <tr><td>0</td><td>2067</td><td>2067</td><td>2067</td><td>2067</td></tr> <tr><td>5</td><td>2059</td><td>2060</td><td>2066</td><td>2060</td></tr> <tr><td>15</td><td>1989</td><td>1994</td><td>2001</td><td>1994</td></tr> <tr><td>25</td><td>1845</td><td>1853</td><td>1864</td><td>1853</td></tr> <tr><td>35</td><td>1636</td><td>1648</td><td>1666</td><td>1648</td></tr> <tr><td>45</td><td>1372</td><td>1393</td><td>1411</td><td>1393</td></tr> <tr><td>55</td><td>1068</td><td>1096</td><td>1109</td><td>1096</td></tr> <tr><td>65</td><td>741</td><td>769</td><td>765</td><td>769</td></tr> <tr><td>75</td><td>416</td><td>419</td><td>407</td><td>419</td></tr> <tr><td>85</td><td>123</td><td>102</td><td>95</td><td>102</td></tr> </tbody> </table>	Vertical Angle	Horizontal Angle				0°	45°	90°	-45°	0	2067	2067	2067	2067	5	2059	2060	2066	2060	15	1989	1994	2001	1994	25	1845	1853	1864	1853	35	1636	1648	1666	1648	45	1372	1393	1411	1393	55	1068	1096	1109	1096	65	741	769	765	769	75	416	419	407	419	85	123	102	95	102	Light Distribution <table border="1"> <thead> <tr> <th rowspan="2">Degrees</th> <th rowspan="2">Lumens</th> <th colspan="2">% Luminaire</th> </tr> <tr> <th>0-30</th> <th>0-60</th> </tr> </thead> <tbody> <tr><td>0-30</td><td>1612</td><td>26.8</td><td></td></tr> <tr><td>0-40</td><td>2644</td><td>44.0</td><td></td></tr> <tr><td>0-60</td><td>4692</td><td>78.1</td><td></td></tr> <tr><td>0-90</td><td>6007</td><td>100.0</td><td></td></tr> </tbody> </table>	Degrees	Lumens	% Luminaire		0-30	0-60	0-30	1612	26.8		0-40	2644	44.0		0-60	4692	78.1		0-90	6007	100.0		Average Luminance <table border="1"> <thead> <tr> <th rowspan="2">Angle</th> <th colspan="3">End 45' Cross</th> </tr> <tr> <th>End</th> <th>45'</th> <th>Cross</th> </tr> </thead> <tbody> <tr><td>45</td><td>3618</td><td>3675</td><td>3721</td></tr> <tr><td>55</td><td>3471</td><td>3562</td><td>3604</td></tr> <tr><td>65</td><td>3269</td><td>3392</td><td>3376</td></tr> <tr><td>75</td><td>2994</td><td>3021</td><td>2934</td></tr> <tr><td>85</td><td>2640</td><td>2187</td><td>2039</td></tr> </tbody> </table>	Angle	End 45' Cross			End	45'	Cross	45	3618	3675	3721	55	3471	3562	3604	65	3269	3392	3376	75	2994	3021	2934	85	2640	2187	2039																													
			Vertical Angle	Horizontal Angle																																																																																																																																								
0°	45°	90°		-45°																																																																																																																																								
0	2067	2067	2067	2067																																																																																																																																								
5	2059	2060	2066	2060																																																																																																																																								
15	1989	1994	2001	1994																																																																																																																																								
25	1845	1853	1864	1853																																																																																																																																								
35	1636	1648	1666	1648																																																																																																																																								
45	1372	1393	1411	1393																																																																																																																																								
55	1068	1096	1109	1096																																																																																																																																								
65	741	769	765	769																																																																																																																																								
75	416	419	407	419																																																																																																																																								
85	123	102	95	102																																																																																																																																								
Degrees	Lumens	% Luminaire																																																																																																																																										
		0-30	0-60																																																																																																																																									
0-30	1612	26.8																																																																																																																																										
0-40	2644	44.0																																																																																																																																										
0-60	4692	78.1																																																																																																																																										
0-90	6007	100.0																																																																																																																																										
Angle	End 45' Cross																																																																																																																																											
	End	45'	Cross																																																																																																																																									
45	3618	3675	3721																																																																																																																																									
55	3471	3562	3604																																																																																																																																									
65	3269	3392	3376																																																																																																																																									
75	2994	3021	2934																																																																																																																																									
85	2640	2187	2039																																																																																																																																									
Coefficients of Utilization EFFECTIVE FLOOR CAVITY REFLECTANCE 20 PER (pfc=0.20)																																																																																																																																												
<table border="1"> <thead> <tr> <th rowspan="2">Ceiling (pcc)</th> <th colspan="3">80%</th> <th colspan="3">70%</th> <th colspan="3">50%</th> </tr> <tr> <th>70</th> <th>50</th> <th>30</th> <th>70</th> <th>50</th> <th>30</th> <th>50</th> <th>30</th> </tr> </thead> <tbody> <tr> <td>Wall (pw)</td> <td>70</td> <td>50</td> <td>30</td> <td>70</td> <td>50</td> <td>30</td> <td>50</td> <td>30</td> </tr> <tr> <td>RCR</td> <td colspan="9">Zonal cavity method - Effective floor reflectance = 20%</td> </tr> <tr> <td rowspan="10">Room Cavity Ratio</td> <td>0</td> <td>118</td> <td>118</td> <td>118</td> <td>115</td> <td>115</td> <td>115</td> <td>111</td> <td>111</td> </tr> <tr><td>1</td><td>109</td><td>104</td><td>98</td><td>106</td><td>101</td><td>96</td><td>96</td><td>93</td></tr> <tr><td>2</td><td>98</td><td>90</td><td>82</td><td>95</td><td>88</td><td>81</td><td>84</td><td>79</td></tr> <tr><td>3</td><td>90</td><td>79</td><td>70</td><td>86</td><td>77</td><td>69</td><td>73</td><td>68</td></tr> <tr><td>4</td><td>81</td><td>69</td><td>60</td><td>80</td><td>68</td><td>59</td><td>66</td><td>58</td></tr> <tr><td>5</td><td>75</td><td>61</td><td>53</td><td>72</td><td>60</td><td>53</td><td>58</td><td>52</td></tr> <tr><td>6</td><td>69</td><td>56</td><td>46</td><td>68</td><td>55</td><td>46</td><td>53</td><td>46</td></tr> <tr><td>7</td><td>65</td><td>51</td><td>41</td><td>63</td><td>50</td><td>41</td><td>47</td><td>40</td></tr> <tr><td>8</td><td>59</td><td>46</td><td>38</td><td>57</td><td>46</td><td>36</td><td>44</td><td>36</td></tr> <tr><td>9</td><td>56</td><td>42</td><td>34</td><td>55</td><td>41</td><td>34</td><td>40</td><td>34</td></tr> <tr><td>10</td><td>53</td><td>39</td><td>30</td><td>51</td><td>39</td><td>30</td><td>38</td><td>30</td></tr> </tbody> </table>				Ceiling (pcc)	80%			70%			50%			70	50	30	70	50	30	50	30	Wall (pw)	70	50	30	70	50	30	50	30	RCR	Zonal cavity method - Effective floor reflectance = 20%									Room Cavity Ratio	0	118	118	118	115	115	115	111	111	1	109	104	98	106	101	96	96	93	2	98	90	82	95	88	81	84	79	3	90	79	70	86	77	69	73	68	4	81	69	60	80	68	59	66	58	5	75	61	53	72	60	53	58	52	6	69	56	46	68	55	46	53	46	7	65	51	41	63	50	41	47	40	8	59	46	38	57	46	36	44	36	9	56	42	34	55	41	34	40	34	10	53	39	30	51	39	30	38	30
Ceiling (pcc)	80%				70%			50%																																																																																																																																				
	70	50	30	70	50	30	50	30																																																																																																																																				
Wall (pw)	70	50	30	70	50	30	50	30																																																																																																																																				
RCR	Zonal cavity method - Effective floor reflectance = 20%																																																																																																																																											
Room Cavity Ratio	0	118	118	118	115	115	115	111	111																																																																																																																																			
	1	109	104	98	106	101	96	96	93																																																																																																																																			
	2	98	90	82	95	88	81	84	79																																																																																																																																			
	3	90	79	70	86	77	69	73	68																																																																																																																																			
	4	81	69	60	80	68	59	66	58																																																																																																																																			
	5	75	61	53	72	60	53	58	52																																																																																																																																			
	6	69	56	46	68	55	46	53	46																																																																																																																																			
	7	65	51	41	63	50	41	47	40																																																																																																																																			
	8	59	46	38	57	46	36	44	36																																																																																																																																			
	9	56	42	34	55	41	34	40	34																																																																																																																																			
10	53	39	30	51	39	30	38	30																																																																																																																																				

2x4 DuaLED, 7300 nominal delivered lumens

LER - 127

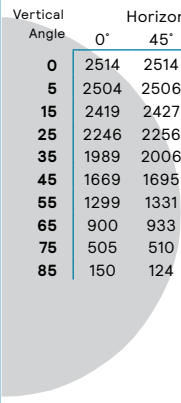
Catalog No. 2DLG73L840-4-D Test No. 36170 S/MH 1.3 Lamp Type LED Lumens/Lamp 7307 Input Watts 57.3 Comparative yearly lighting energy cost per 1000 lumens - \$1.88 based on 3000 hrs. and \$.08 pwr KWH. The photometric results were obtained in the Day-Brite laboratory which is NVLAP accredited by the National Institute of Standards and Technology. Photometric values based on test performed in compliance with LM-79.	Candela distribution  <table border="1"> <thead> <tr> <th rowspan="2">Vertical Angle</th> <th colspan="4">Horizontal Angle</th> </tr> <tr> <th>0°</th> <th>45°</th> <th>90°</th> <th>-45°</th> </tr> </thead> <tbody> <tr><td>0</td><td>2514</td><td>2514</td><td>2514</td><td>2514</td></tr> <tr><td>5</td><td>2504</td><td>2506</td><td>2513</td><td>2506</td></tr> <tr><td>15</td><td>2419</td><td>2427</td><td>2434</td><td>2427</td></tr> <tr><td>25</td><td>2246</td><td>2256</td><td>2266</td><td>2256</td></tr> <tr><td>35</td><td>1989</td><td>2006</td><td>2026</td><td>2006</td></tr> <tr><td>45</td><td>1669</td><td>1695</td><td>1716</td><td>1695</td></tr> <tr><td>55</td><td>1299</td><td>1331</td><td>1348</td><td>1331</td></tr> <tr><td>65</td><td>900</td><td>933</td><td>931</td><td>933</td></tr> <tr><td>75</td><td>505</td><td>510</td><td>496</td><td>510</td></tr> <tr><td>85</td><td>150</td><td>124</td><td>117</td><td>124</td></tr> </tbody> </table>	Vertical Angle	Horizontal Angle				0°	45°	90°	-45°	0	2514	2514	2514	2514	5	2504	2506	2513	2506	15	2419	2427	2434	2427	25	2246	2256	2266	2256	35	1989	2006	2026	2006	45	1669	1695	1716	1695	55	1299	1331	1348	1331	65	900	933	931	933	75	505	510	496	510	85	150	124	117	124	Light Distribution <table border="1"> <thead> <tr> <th rowspan="2">Degrees</th> <th rowspan="2">Lumens</th> <th colspan="2">% Luminaire</th> </tr> <tr> <th>0-30</th> <th>0-60</th> </tr> </thead> <tbody> <tr><td>0-30</td><td>1961</td><td>26.8</td><td></td></tr> <tr><td>0-40</td><td>3216</td><td>44.0</td><td></td></tr> <tr><td>0-60</td><td>5707</td><td>78.1</td><td></td></tr> <tr><td>0-90</td><td>7308</td><td>100.0</td><td></td></tr> </tbody> </table>	Degrees	Lumens	% Luminaire		0-30	0-60	0-30	1961	26.8		0-40	3216	44.0		0-60	5707	78.1		0-90	7308	100.0		Average Luminance <table border="1"> <thead> <tr> <th rowspan="2">Angle</th> <th colspan="3">End 45' Cross</th> </tr> <tr> <th>End</th> <th>45'</th> <th>Cross</th> </tr> </thead> <tbody> <tr><td>45</td><td>4402</td><td>4470</td><td>4525</td></tr> <tr><td>55</td><td>4222</td><td>4329</td><td>4384</td></tr> <tr><td>65</td><td>3973</td><td>4117</td><td>4108</td></tr> <tr><td>75</td><td>3641</td><td>3671</td><td>3570</td></tr> <tr><td>85</td><td>3216</td><td>2655</td><td>2495</td></tr> </tbody> </table>	Angle	End 45' Cross			End	45'	Cross	45	4402	4470	4525	55	4222	4329	4384	65	3973	4117	4108	75	3641	3671	3570	85	3216	2655	2495																													
			Vertical Angle	Horizontal Angle																																																																																																																																								
0°	45°	90°		-45°																																																																																																																																								
0	2514	2514	2514	2514																																																																																																																																								
5	2504	2506	2513	2506																																																																																																																																								
15	2419	2427	2434	2427																																																																																																																																								
25	2246	2256	2266	2256																																																																																																																																								
35	1989	2006	2026	2006																																																																																																																																								
45	1669	1695	1716	1695																																																																																																																																								
55	1299	1331	1348	1331																																																																																																																																								
65	900	933	931	933																																																																																																																																								
75	505	510	496	510																																																																																																																																								
85	150	124	117	124																																																																																																																																								
Degrees	Lumens	% Luminaire																																																																																																																																										
		0-30	0-60																																																																																																																																									
0-30	1961	26.8																																																																																																																																										
0-40	3216	44.0																																																																																																																																										
0-60	5707	78.1																																																																																																																																										
0-90	7308	100.0																																																																																																																																										
Angle	End 45' Cross																																																																																																																																											
	End	45'	Cross																																																																																																																																									
45	4402	4470	4525																																																																																																																																									
55	4222	4329	4384																																																																																																																																									
65	3973	4117	4108																																																																																																																																									
75	3641	3671	3570																																																																																																																																									
85	3216	2655	2495																																																																																																																																									
Coefficients of Utilization EFFECTIVE FLOOR CAVITY REFLECTANCE 20 PER (pfc=0.20)																																																																																																																																												
<table border="1"> <thead> <tr> <th rowspan="2">Ceiling (pcc)</th> <th colspan="3">80%</th> <th colspan="3">70%</th> <th colspan="3">50%</th> </tr> <tr> <th>70</th> <th>50</th> <th>30</th> <th>70</th> <th>50</th> <th>30</th> <th>50</th> <th>30</th> </tr> </thead> <tbody> <tr> <td>Wall (pw)</td> <td>70</td> <td>50</td> <td>30</td> <td>70</td> <td>50</td> <td>30</td> <td>50</td> <td>30</td> </tr> <tr> <td>RCR</td> <td colspan="9">Zonal cavity method - Effective floor reflectance = 20%</td> </tr> <tr> <td rowspan="10">Room Cavity Ratio</td> <td>0</td> <td>118</td> <td>118</td> <td>118</td> <td>115</td> <td>115</td> <td>115</td> <td>111</td> <td>111</td> </tr> <tr><td>1</td><td>109</td><td>104</td><td>98</td><td>106</td><td>101</td><td>96</td><td>96</td><td>93</td></tr> <tr><td>2</td><td>98</td><td>90</td><td>82</td><td>95</td><td>88</td><td>81</td><td>84</td><td>79</td></tr> <tr><td>3</td><td>90</td><td>79</td><td>70</td><td>86</td><td>77</td><td>69</td><td>73</td><td>68</td></tr> <tr><td>4</td><td>81</td><td>69</td><td>60</td><td>80</td><td>68</td><td>59</td><td>66</td><td>58</td></tr> <tr><td>5</td><td>75</td><td>61</td><td>53</td><td>72</td><td>60</td><td>53</td><td>58</td><td>52</td></tr> <tr><td>6</td><td>69</td><td>56</td><td>46</td><td>68</td><td>55</td><td>46</td><td>53</td><td>46</td></tr> <tr><td>7</td><td>65</td><td>51</td><td>41</td><td>63</td><td>50</td><td>41</td><td>47</td><td>40</td></tr> <tr><td>8</td><td>59</td><td>46</td><td>38</td><td>57</td><td>46</td><td>36</td><td>44</td><td>36</td></tr> <tr><td>9</td><td>56</td><td>42</td><td>34</td><td>55</td><td>41</td><td>34</td><td>40</td><td>34</td></tr> <tr><td>10</td><td>53</td><td>39</td><td>30</td><td>51</td><td>39</td><td>30</td><td>38</td><td>30</td></tr> </tbody> </table>				Ceiling (pcc)	80%			70%			50%			70	50	30	70	50	30	50	30	Wall (pw)	70	50	30	70	50	30	50	30	RCR	Zonal cavity method - Effective floor reflectance = 20%									Room Cavity Ratio	0	118	118	118	115	115	115	111	111	1	109	104	98	106	101	96	96	93	2	98	90	82	95	88	81	84	79	3	90	79	70	86	77	69	73	68	4	81	69	60	80	68	59	66	58	5	75	61	53	72	60	53	58	52	6	69	56	46	68	55	46	53	46	7	65	51	41	63	50	41	47	40	8	59	46	38	57	46	36	44	36	9	56	42	34	55	41	34	40	34	10	53	39	30	51	39	30	38	30
Ceiling (pcc)	80%				70%			50%																																																																																																																																				
	70	50	30	70	50	30	50	30																																																																																																																																				
Wall (pw)	70	50	30	70	50	30	50	30																																																																																																																																				
RCR	Zonal cavity method - Effective floor reflectance = 20%																																																																																																																																											
Room Cavity Ratio	0	118	118	118	115	115	115	111	111																																																																																																																																			
	1	109	104	98	106	101	96	96	93																																																																																																																																			
	2	98	90	82	95	88	81	84	79																																																																																																																																			
	3	90	79	70	86	77	69	73	68																																																																																																																																			
	4	81	69	60	80	68	59	66	58																																																																																																																																			
	5	75	61	53	72	60	53	58	52																																																																																																																																			
	6	69	56	46	68	55	46	53	46																																																																																																																																			
	7	65	51	41	63	50	41	47	40																																																																																																																																			
	8	59	46	38	57	46	36	44	36																																																																																																																																			
	9	56	42	34	55	41	34	40	34																																																																																																																																			
10	53	39	30	51	39	30	38	30																																																																																																																																				