

**BloomBox** brings the next generation of Ledalite's Luminous Environmental Design Approach to life with high efficacy, low glare, modular optics, and sustainability benefits that offer illumination without compromise.

Project: \_\_\_\_\_  
 Location: \_\_\_\_\_  
 Cat.No: \_\_\_\_\_  
 Type: \_\_\_\_\_  
 Line ID: \_\_\_\_\_ Qty: \_\_\_\_\_  
 Notes: \_\_\_\_\_

**Ordering guide**

Example: BB22D1STL94030Y1DSNCS

Family	Size	Version	Configuration	Source	CRI/CCT	Lumens
BB	22	D1	ST	L		
BB BloomBox	22 2'x2'	D1 Standard T-Grid	ST Standalone	L LED	940 CRI 90, 4000K 935 CRI 90, 3500K	50 5000lm 40 4000lm 30 3000lm
Optics	Wiring	Voltage	Driver	Option	Systems/Controls	
Y	1	D				
Y Micro Cell Optics with 3D Batwing	1 Single Circuit	D UNV 120-277V	E Advance Xitanium 0-10V (1% Dim) S Advance Xitanium SR, DALI-2 D4i (1%)	None	Leave blank with 0-10V driver  CS Interact Pro scalable wireless sensor with integral daylight & occupancy sensing, advanced grouping with dwell time SB Interact wireless sensor bundle with occupancy, daylight, and environmental sensing capabilities	

**Leaf pattern**

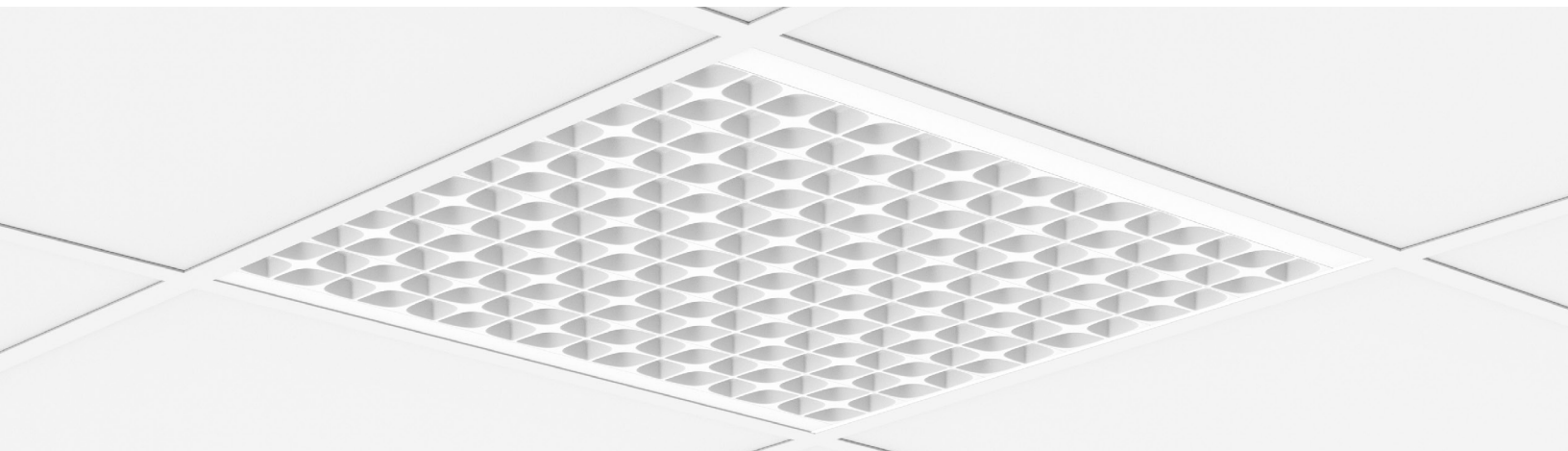

# BloomBox recessed

2'x2'

## Dimensions

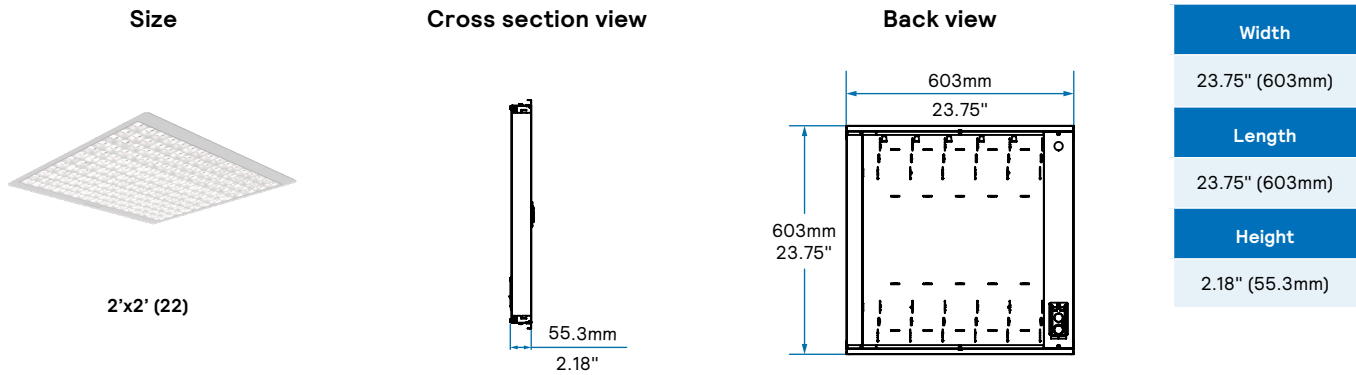

## Mounting details

### Flat T-Grid

Integrates with most common T-Grid types. Works with 9/16" & 15/16" flat T-Grid ceilings

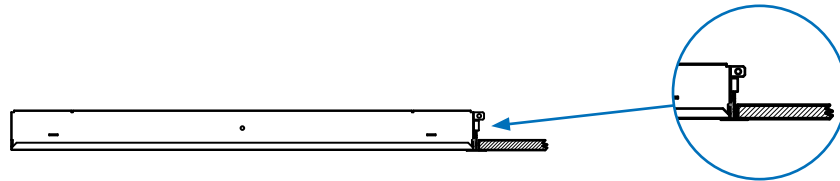

### Slot T-Grid

Can be used with slot T-Grid ceilings. For 9/16" slot T-Grid ceilings, fixture will sit 5/16" above bottom of T-Bar.

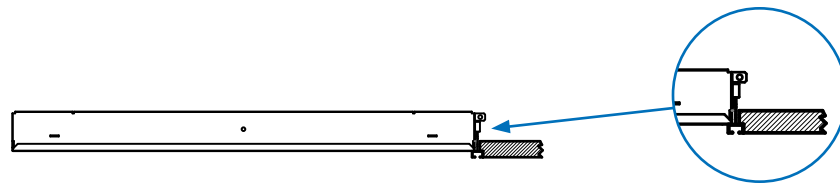

## Drywall Trim Kit

The drywall trim kit mounting frame assembly is designed to permit use of grid (NEMA G) fixtures in drywall or ceilings requiring flanges. Finish is white.

Extruded aluminum construction with mitered corners. Includes screws for complete assembly.

**Drywall kit ordering code is 300DK03**

More information available at: [http://docs.ledalite.com/download/pdf/ID-Recessed\\_Drywall\\_Kits.pdf](http://docs.ledalite.com/download/pdf/ID-Recessed_Drywall_Kits.pdf)

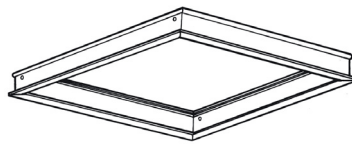

## Wood Frame

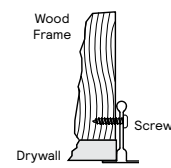

Wood frame and screws supplied by others.

## Hanger Wire

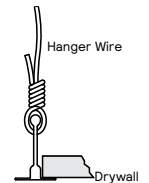

Hanger wires supplied by others.

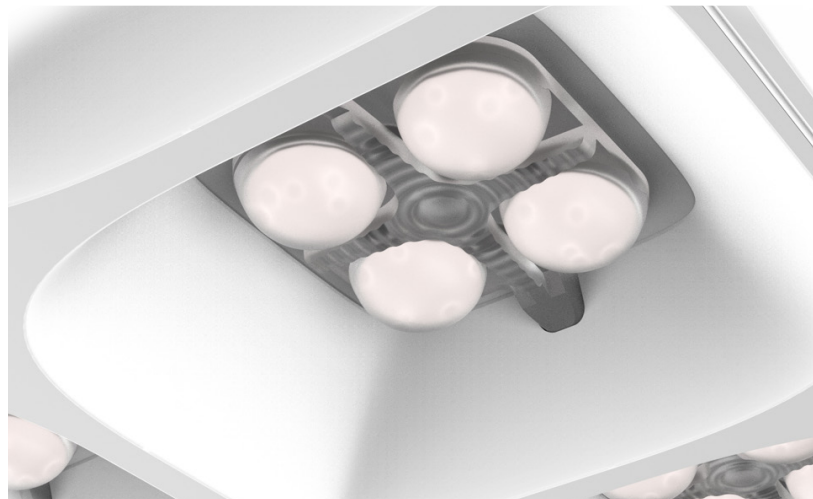
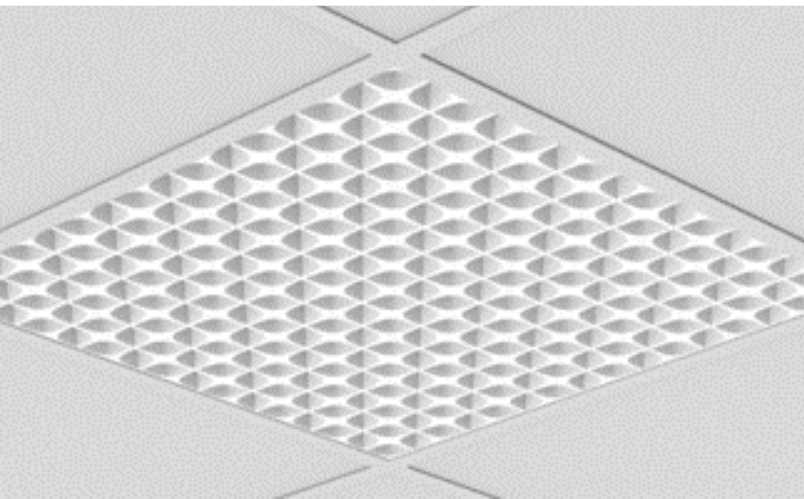

# BloomBox recessed

## 2'x2'

### Specifications

#### Optical System

BloomBox's unique optical system provides an unparalleled mix of efficacy, spacing, and glare control. The 2'x2' utilizes six field removable modules providing high-performance lighting complemented by the white Leaf pattern overlay for enhanced glare control and aesthetic appeal.

#### Finish

Housing and frame painted: high quality, powder coated white only.

#### Housing

Sides and center spine: precision aluminum extrusion; end caps, back housing and driver cover: die-formed, 20 gauge cold-rolled steel, pre and post painted. Available in white. Optics are RAL 9003.

#### Weight

Maximum 14.5 lbs.

#### Mounting

Fixtures are factory pre-wired and tested. Compatible with 15/16" lay-in acoustical ceilings using exposed grid suspension (NEMA type G). For 9/16" slot T-grid ceilings, fixture will sit 5/16" above bottom of t-grid. Optional drywall kit trim mount can be fastened to a wood frame or with hangar wire.

#### Standard Driver

Advance Xitanium 0-10V, 1% dimming.

Advance Xitanium Sensor Ready (SR), 1% dimming (Advance SR Driver is DALI-2 and D4i compatible).

Class 2 rated output.

Consult Ledalite for other available drivers.

#### Lumen Maintenance

LEDs have been tested by the manufacturer in accordance with IESNA LM-80-08. At an ambient temperature of 25°C, the LED lumen maintenance expectation according to IES TM-21-11:  $L_{70}$  (12k) >72,000 hrs (Reported methodology)

Signify's proprietary luminaire lifetime prediction model predicts that the actual lumen maintenance is:  $L_{90}$  (12k) > 97,000 hrs (Calculated)

#### Source Color

LEDs rated for color rendering of: CRI >90 & R9 >60

Fixture to fixture color accuracy within: 2 SDCM for Static White luminaires

#### Warranty

Five-year luminaire limited warranty including LED boards and driver.

[www.signify.com/warranties](http://www.signify.com/warranties)

#### Environment

Rated for dry & damp locations in operating ambient temperatures of 0-25°C (32-77°F). Many luminaire components, such as reflectors, refractors, lenses, and LEDs are made from various types of plastics which can be adversely affected by airborne contaminants. If sulfur based chemicals, petroleum based products, cleaning solutions, or other contaminants are expected in the intended area of use, consult factory for compatibility. Damage caused by sulfur, chlorine, petroleum based solution or other contaminants are not covered under warranty.

#### WELL v2 Building Standard

BloomBox luminaires contribute towards satisfying the following features under the WELL v2 Building Standard:

**L03:** When specified with the Tunable White system. Consult factory for BloomBox Tunable White options.

**L04:** Glare management with all configurations at <19 UGR.

**L07:** Brightness management with batwing distributions allowing for even lighting within a space, while spacing the fixtures wider apart than a typical recessed luminaire product.

**L08:** AccuRender CRI 90 standard LED boards with high performance Advance drivers (or optional drivers) to manage color quality and flicker

**L09:** When specified with Interact or when tied to a 3rd party control system.

**X07:** Materials Transparency via the Declare label, operated by the International Living Future Institute.

#### Approvals

Certified to UL, CSA, and IES standards.

All BloomBox configurations listed on this spec sheet are DesignLights Consortium Premium qualified. Please see the DLC QPL list for exact catalog numbers under DLC Family Code RRRYGK. [www.designlights.org/QPL](http://www.designlights.org/QPL).

BloomBox is Declare label certified. More information on the BloomBox label can be found on [www.declare.living-future.org](http://www.declare.living-future.org).

Luminaires that include Interact Pro controls options can help meet the requirements in 90.1-2022, IECC 2021, and CA T24 2022 for a maximum of 20 min. time out for occupancy controls.

**Declare.**

**Ledalite Luminaires: BloomBox, SilkSpace Def., BoldPlay, Sonata, FloatPlane (BB/42/78/77/24) Genlyte Solutions by Signify**

**Final Assembly:** Langley, British Columbia, Canada; Monterrey, Nuevo Leon, Mexico; Littlestown, Pennsylvania, USA  
**Life Expectancy:** 10+ Year(s)  
**End of Life Options:** Recyclable (90% where facilities exist), Landfill (10%)

**Ingredients:**  
Iron; Small Electrical Components - RoHS Compliant<sup>1</sup>; Carbonic acid; polymer with 4,4'-(1-methylethylidene)bis[phenol]; 2-Propenoic acid, 2-methyl-, methyl ester, polymer with ethyl 2-propenoate; Aluminum; Polyethylene Terephthalate; Copper; Titanium dioxide; Chromium alloy, base, Cr 52-72, Fe 17-31, Si 3-14, C 4-9.5 (ASTM A101-HIGH CARBON); Nickel (Metallic); Fatty acids, castor oil, caustic-oxidized, dist.; residues, esters with 1,3-butenediol; Ethyl acrylate; Chromium, metallic; Poly(imino(1,6-dioxo-1,6-hexanedyl)imino-1,6-hexanedyl); **Polyvinyl chloride**; Barium sulfate; Silicon; Manganese; Tungsten; Zinc; Cobalt metal powder; Tris(2-ethylhexyl) trimellitate; Molybdenum; Acrylonitrile-Butadiene-Styrene Copolymer; Steel; Polyethylene; Graphite; Niobium; Vanadium; Silicone; Titanium; Silver; Pulp, cellulose; Urethane (Ethyl carbamate); 1,3,5-Triglycidyl-s-triazinetrione; Amorphous silica; Calcium Carbonate; Kaolin, calcined; Sulfur, Elemental; Phosphorus; Nitrogen; Poly(oxy-1,4-butanediylloxycarbonyl-1,4-phenylene)carbonyl; Polyamide fibers; Polyphosphoric acids; Polyolefin aryl amine; 1-Propene, polymer with ethene; Methyl methacrylate; Tin, Organic; Boron; Antimony oxide (Antimony trioxide); Carbon black; Magnesium; Bicyclo[2.2.1]hept-2-ene, 5-ethylidene-, polymer with ethene and 1-propene; POLYOLEFIN; Melamine cyanurate; Hydrocarbon oils; Talc; 1,3,5-Triazine-2,4,6-triamine, phosphate (1:1); Ethyl acrylate; Acetic acid etheryl ester, polymer with ethene; Polypropylene

<sup>1</sup>LBC Temp Exception RL-002 - Small Electrical Components

**Living Building Challenge Criteria:**

**I-13 Red List:**  
 LBC Red List Free % Disclosed: 100% at 100ppm  
 LBC Red List Approved VOC Content: Not Applicable  
 Declared

**I-10 Interior Performance:** Not Applicable  
**I-14 Responsible Sourcing:** Not Applicable

SGY-0008  
EXP. 01 MAY 2026  
Original Issue Date: 2024

MANUFACTURER RESPONSIBLE FOR LABEL ACCURACY  
INTERNATIONAL LIVING FUTURE INSTITUTE™ [living-future.org/declare](http://living-future.org/declare)

# BloomBox recessed

2'x2'

## Wireless Controls Options

### Interact sensor for Standalone & Gateway tiers (CS):

- CS is a connected sensor with integral occupancy and daylight sensing and supports wireless mesh connectivity.
- The sensor works in the Standalone mode when configured without a gateway or in Gateway mode if a compatible gateway is used.
- Interact includes an App, a portal and a broad portfolio of wireless luminaires, lamps and retrofit kits all working on the same system.
- Startup is implemented via Interact Pro App (Android or iPhone) & Bluetooth connectivity. The App provides flexibility to choose between a gateway or non-gateway (Standalone) mode for setup.
- Setup with the gateway requires wired internet access to the gateway. It is possible to add a gateway at a later point.
- Prepare project configuration steps remotely and use IRT9015 remote onsite to identify and group devices together.
- Compatible with UID8451/10 wireless dimmer switch, SWS200 wireless scene switch, wireless Occ sensor (OCC SENSOR IA CM IP42 WH 10/1) and wireless Day/Occ sensor (OCC MULTI SENSOR IA CM WH 10/1).
- For more information on Interact visit:  
<https://www.interact-lighting.com/en-us/what-is-possible/about-interact>

### Emergency Options (R):

- Power Sensing (Factory default) – Recommended
- UL924 option requires unswitched power sense line, absence of voltage on the normal circuit triggers luminaire to 100% output.
- Power Interruption Detection (Field option)
- Detects AC power interruption >30ms triggers 90 minute emergency mode with luminaire at 100% output.

### Interact sensor bundles for Gateway + IoT tier (SB):

- SB option, in addition to occupancy and daylight sensing, supports advanced IoT capabilities such as people estimation analysis, desk level temperature & humidity sensing, noise classification, and BLE beacon.
- Compatible with UID8451/10 wireless dimmer switch, SWS200 wireless scene switch, wireless Occ sensor (OCC SENSOR IA CM IP42 WH 10/1) and wireless Day/Occ sensor (OCC MULTI SENSOR IA CM WH 10/1).
- Use Interact software and insights to increase building efficiency, achieve building wide integration and optimize space through occupancy analytics.
- Requires compatible Gateway and internet connectivity for commissioning. For more information, visit: [www.interact-lighting.com/office](http://www.interact-lighting.com/office)

### Lutron Athena and Vive (AS and VS):

- Lutron Athena (AS = AWNS) and Lutron Vive (VS = VDO) integral fixture control available with Advance SR drivers. See Lutron website for additional details and specs: <https://commercial.lutron.com/>

## Wired Controls Options

### Interact Office Wired PoE (IO & SB):

- PoE based IoT connected lighting solution for large enterprises that span across multiple floors, buildings and require multiple gateways.
- Use Interact software and insights to increase building efficiency, achieve building wide integration and optimize space through occupancy analytics.
- Integral sensor option for occupancy sensing (PIR) and/or daylight harvesting available for additional energy savings.
- SB option, in addition to occupancy and daylight sensing, supports advanced IoT capabilities such as people estimation analysis, desk level temperature & humidity sensing, noise classification, and BLE beacon.
- Optional integral emergency controller and battery pack provides backup lighting in the case of a power outage. Test switch and indicator light mounted on the chassis.
- Emergency battery has a 3 month pre-installed shelf life, and must be stored and installed in environments of -20°C to 30°C (-4F to 86F) ambient, and 45-85% relative humidity.
- For more information on Interact Office Wired visit:  
[www.interact-lighting.com/office](http://www.interact-lighting.com/office)

Note: For this option luminaires are not sold individually and are only compatible with Signify's Interact Office control system & software. The system requires a compatible back-end IT infrastructure for normal operations, please consult your Signify representative for additional information.

### Tunable White:

- Tunable White is available in Interact Office Wired PoE luminaires. Other control options for Tunable White with DALI (DT6 or DT8), 0-10V, Lutron T Series or DMX control are available via an Engineered-to-Order (ETO) request.
- Signify tunable white solutions are designed to help maximize the influence of lighting on your daily life.
- Dynamic behaviors via scheduled lighting recipes mimicking daylight patterns or supporting biorhythms.
- Scene setting via lighting pre-sets based on various combinations of lighting color temperature and intensity.

Interact sensor option codes across Genlyte product lines

	Evokit	Day-Brite	Ledalite	Lightolier
Zigbee + Bluetooth + Sensing	SWZCS	SWZCS	CS	SBA accessory (external)
Zigbee + Bluetooth	RADIO	RADIO	RA	RA
Zigbee + Bluetooth + Sensing + Environmental data	IAOSB	IAOSB	SB	SB
Zigbee + Highbay + Sensing	-	SWZCSH	-	-

# BloomBox recessed

2'x2'

## Functionalities overview

Interact system			
	Standalone	Gateway	Gateway + IoT
Dimming, grouping, and zoning	✓	✓	✓
Bluetooth and ZigBee enabled	✓	✓	✓
Motion sensing and daylight harvesting	✓	✓	✓
Integration with 0-10V and phase dimming fixtures	✓	✓	✓
Code compliance	✓	✓	✓
Granular dimming and dwell time	✓	✓	✓
<b>New</b> Correlated color temperature (CCT) tuning by switch	✓	✓	✓
<b>New</b> Support for sensor-based Tunable White luminaires	✓	✓	✓
Energy reporting and monitoring		✓	✓
Scheduling		✓	✓
Demand response		✓	✓
BMS integration (BACnet)			✓
Floor plan visualization			✓
IoT sensors for wellness			✓
IoT Apps for productivity			✓

## Currently supported maximum system size

To be able to design the lighting system correctly for the customer, it is important to know the prime characteristics of the system, its possibilities and limitations.

System level	
Total number of gateways	Unlimited
Total number of devices	200 per network
• luminaires with integrated sensors	150
• smart TLEDs	150
Total number of ZGP devices (sensors and switches)	50
• sensors	30
• switches	50
• zones and groups	64
Group level	
Recommended number of lights	40 (recommended 25)
Number of ZGP devices	5
Number of scenes	16

## Interact system architecture for office, education, healthcare, retail and industrial applications

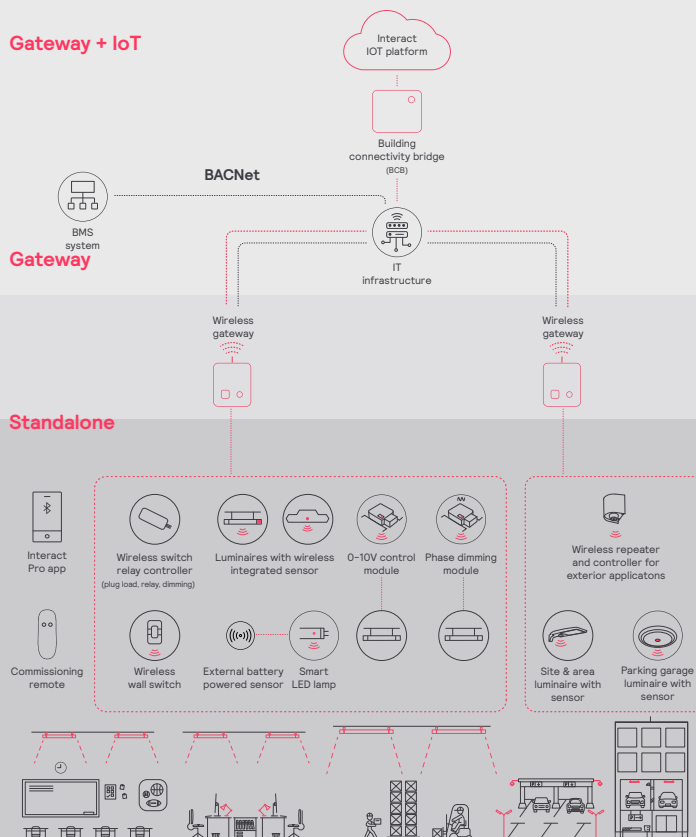

# BloomBox recessed

## 2'x2'

### Colorimetry

#### BloomBox Recessed 2'x2'

Nominal CRI & CCT		CRI 90, 3500K	CRI 90, 4000K
CIE 013.3-1995 <sup>1</sup>	CRI R <sub>a</sub>	93	93
	R <sub>9</sub>	62	60
	G <sub>a</sub>	99	97
	C <sub>a</sub>	93	93
IES TM-30-18 <sup>2</sup>	R <sub>f</sub>	91	89
	R <sub>f</sub> , h <sub>1</sub>	90	88
	R <sub>g</sub>	100	97
	R <sub>cs</sub> , h <sub>1</sub>	-5%	-6%
MDER <sup>3</sup>		0.56	0.64

- Color Rendering Index (CRI Ra) and Strong Red (R9) are calculated in accordance with CIE 013.3-1995. Color Gamut index (Ga) and red chroma index (C9) are CIE based properties using the Global Lighting Association's calculation tool.
- Fidelity Index (Rf), Red Fidelity Index (Rf,h1), Gamut Index (Rg), and Red Local Chroma Shift (Rcs,h1) are calculated in accordance with IES TM-30-18.-18.
- Melanopic Daylight Efficacy Ratio (MDER) is the measure for "spectral melanopic efficiency" as defined in CIE S 026-2018.

### Photometry

#### BloomBox Recessed 2'x2'

Click "PDF" or "IES" text to download

Nominal CRI & CCT		CRI 90, 3500K					CRI 90, 4000K				
Size & Nominal Lumen Package	Watts (W)	Flux (lm) <sup>1</sup>	Efficacy (LPW) <sup>2</sup>	UGR <sup>2</sup>	Photometry Report	IES File	Flux (lm) <sup>1</sup>	Efficacy (LPW) <sup>2</sup>	UGR <sup>2</sup>	Photometry Report	IES File
2'x2' - 5000lm	29.4	4869	165	18.6	PDF	IES	5008	170	18.7	PDF	IES
2'x2' - 4000lm	23.4	3901	166	17.8	PDF	IES	4003	171	17.9	PDF	IES
2'x2' - 3000lm	17.5	2914	166	16.8	PDF	IES	2989	171	16.9	PDF	IES

- Luminaire photometry has been conducted in accordance with IES LM-79-08. IES files can be downloaded by clicking the links in the table above, or online at ledalite.com.
- Unified Glare Rating (UGR) is calculated in accordance with CIE 117-1995. Reference conditions of 4Hx8Hx1H and reflectances of 70/50/20% have been applied using the procedure described in CIE 190-2010.

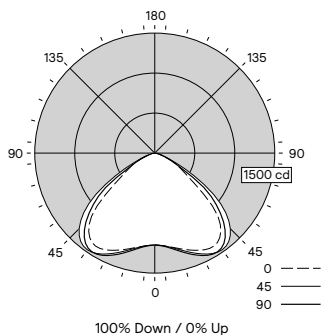

Photometric data shown is for 4000lm, CRI 90, 4000K configuration.